

Panasonic®

Operating Manual

Document Scanner

Model No. KV-S5076H
KV-S5046H

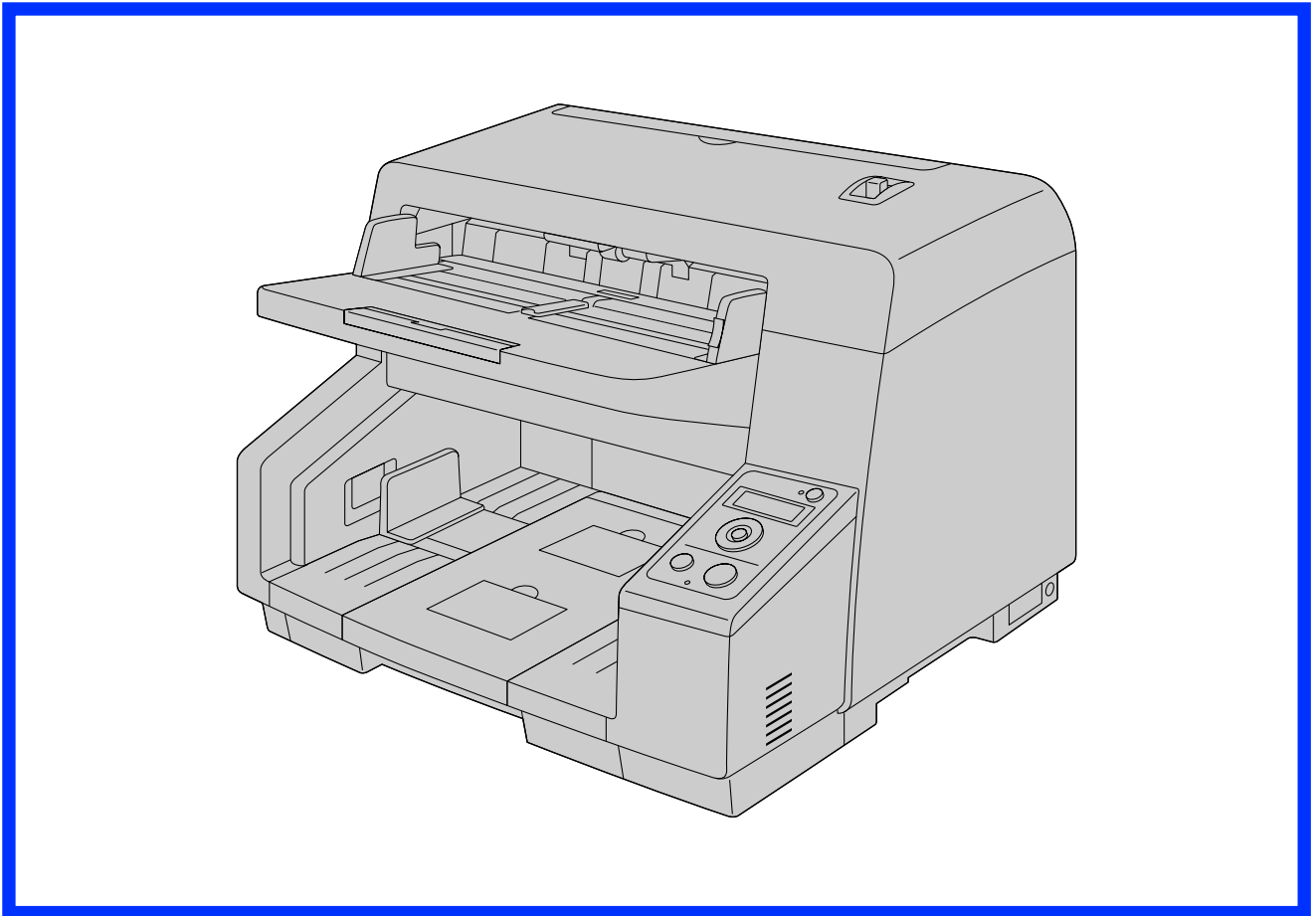

These instructions contain information on operating the scanner. Before reading these instructions, please read the Quick Installation Guide enclosed with this unit.

Keep all documentation in a safe place for future reference.

Introduction

Thank you for purchasing a Panasonic Document Scanner.

Feature Highlights

Superior Paper Feeding

- This scanner features an advanced paper-feeding mechanism that adjusts the pressure of the rollers and the amount of time that the rollers are applied to the document according to the condition of the document. As a result, this scanner can scan a wide range of paper weights, from very thin 20 g/m² (5 lb.) paper to very thick 157 g/m² (42 lb.) paper.

High-speed Double Sided Scanning

- This scanner can scan documents at high speed, regardless of the image type (monochrome / color).
Single sided: 100 pages/minute, double sided: 200 images/minute (200 dpi, 300 dpi) for KV-S5076H
Single sided: 80 pages/minute, double sided: 160 images/minute (200 dpi, 300 dpi) for KV-S5046H
* Speeds based on scanning A4 size paper in landscape orientation.

Support for High-efficiency Scanning Jobs

- Self-cleaning function
This scanner has self-cleaning brushes that clean paper dust off of the scanning glass. The KV-S5076H also contains an ionizer that, by emitting ions, reduces the amount of paper dust that accumulates on the scanning glass.
- Stapled document detection (KV-S5076H only)
This scanner has a stapled document detection that detects documents that contain staples and stops scanning before any serious damage occurs.
- Background color switch function
Using the software, you can switch the background color of scanned images between white and black.
- Mechanical deskew (KV-S5076H only)
In addition to adjusting skewed documents via the software (deskew), this scanner supports the mechanical deskew function that detects skew in documents before they are scanned, and adjusts the document using the feeding mechanism. With this function, you can reduce the various problems that arise from skewed documents.
- Double feed detection function
This scanner contains ultrasonic sensors that detect double feeding. Double feeding can be detected even if you scan documents that contain paper of various thicknesses.
- Double Feed Skip (DFS) function
If scanning has been stopped because a double feed was detected, you can easily resume scanning by pressing the Skip button (SKIP). When you scan documents that include items that you do not want to be detected as double feeding (for example, documents that have receipts attached, envelopes, etc.), the double feed detection function can be enabled and still scan these documents.

Other Features

- You can set the left and right document guides independently. By doing so, you can reliably scan documents of differing paper sizes.
- The paper feed path can be opened widely to easily remove jammed paper and perform maintenance.
- This scanner has a counter function which indicates the approximate time for cleaning and replacement of the rollers. The counters can be configured and checked in User Utility.

About the Documentation

The scanner documentation consists of 2 manuals: the Operating Manual (this manual), and the Quick Installation Guide.

Operating Manual (this manual)	This manual provides all information required to use the unit.
Quick Installation Guide	The Quick Installation Guide explains about safety precautions and other important information, and outlines brief installation procedures of the unit and software.

About the Software Help

Each software contains help files.

For details about viewing the help files, see "To view the help" (page 22).

Software / Manual CD-ROM Contents

Drivers	Device Driver
	TWAIN
	ISIS
Applications	Image Capture Plus ^{*1}
Utilities	User Utility
	Scan Button Setting Tool
Documents^{*2}	Operating Manual
	Control sheet ^{*3}

^{*1} Image Capture Plus is a Panasonic original application for configuring advanced scanning settings.

^{*2} Each document is a PDF document. To view documents correctly, install Adobe® Reader®.

^{*3} For details about the control sheet, see "Using Control Sheets" (page 42).

System Requirements

Computer	IBM® PC/AT or compatible machine with a CD-ROM drive
CPU	Intel® Core™2 Duo 1.8 GHz or higher
Interface	USB 2.0 / USB 3.0

Note

- For details about the system requirements, refer to [Read me first] in the Software / Manual CD-ROM.
- The scanning speed differs depending on the host computer's operating environment or the application used.
- Due to the slower speed of USB 1.1, it is recommended to use a USB 2.0 / USB 3.0 interface.
- If you connect the unit to a USB hub, it is not guaranteed to work.

Abbreviations

- Windows® refers to the Microsoft® Windows® operating system (hereafter Windows).
- Windows® XP refers to the Microsoft® Windows® XP operating system (hereafter Windows XP).
- Windows Vista® refers to the Microsoft® Windows Vista® operating system (hereafter Windows Vista).
- The explanations and screen shots in this manual are based on the Windows 7 operating system.
- The screen shots used in this manual may differ from the screens displayed on your computer.
- The illustrations in this manual are based on the KV-S5076H.

Trademarks

- Microsoft, Windows, Windows Vista, and Internet Explorer are either registered trademarks or trademarks of Microsoft Corporation in the United States and/or other countries.
- ISIS is a registered trademark or trademark of EMC Corporation in the United States and other countries.
- IBM is a trademark of International Business Machines Corporation in the United States, other countries, or both.
- Intel and Intel Core are trademarks of Intel Corporation in the U.S. and other countries.
- Adobe and Adobe Reader are either registered trademarks or trademarks of Adobe Systems Incorporated in the United States and/or other countries.
- All other trademarks identified herein are the property of their respective owners.

About Consumables and Optional Accessories

Consumables and optional accessories available for this unit are as follows:

- Consumables
 - Roller exchange kit (Part No.: KV-SS060)
 - Roller cleaning paper (Part No.: KV-SS03)
 - Ink cartridge (Part No.: KV-SS021)
- Optional Accessories
 - Imprinter unit (Part No.: KV-SS014)

For details, see "Consumables and Optional Accessories" (page 60).

Table of Contents

Before You Start	8
Precautions	8
Check the Accessories	10
Location of Controls	11
Main Unit	11
Front	11
Rear	12
Control Panel and LED Indicators	13
Installation	15
About the Installation Location	15
Installing the Unit	16
Installing the Software	20
Viewing Operating Manual and Help Installed	22
Operation	23
Preparing Documents	23
Acceptable Documents	23
Unacceptable Documents	25
Notes about documents for scanning	25
Scanning Documents	26
When Scanning Documents Manually	31
When Scanning Documents with Pages of Different Sizes at One Time	32
When Changing the Scanned Data Background Color	38
Starting Up Scanner Applications Automatically	39
Performing push scan using the LCD (KV-S5076H only)	41
Using Control Sheets	42
About Printing Control Sheets	43
Clearing Paper Jams	45
Clearing Paper Jams	45
Care and Maintenance	48
Cleaning the Outside of the Scanner	48
Cleaning the Inside of the Scanner	49
Cleaning the Conveyor	53
Cleaning the Ion Outlets and Sensors	54
Cleaning the Rollers	56
Cleaning the Scanning Backgrounds	58
Cleaning the Scanning Glasses	59
Consumables and Optional Accessories	60
Consumables and Optional Accessories	60
Replacing the Rollers	61
Installing Optional Accessories	67
Installing the Imprinter Unit and Ink Cartridge	67
How to Remove the Ink Cartridge	71
Printing	73
Appendix	74
Troubleshooting	74

Error Messages (KV-S5076H only)77
Shading Adjustment78
Deleting Installed Software79
Repacking Instructions80
Specifications82
Index.....84

Precautions

Illegal Duplication

It is unlawful to make duplication of certain documents.

Duplicating certain documents may be illegal in your country/area.

Penalties of fines and/or imprisonment may be imposed on those found guilty. The following are examples of items that may be illegal to duplicate in your country/area.

- Currency
- Bank notes and checks
- Bank and government bonds, and securities
- Passports, licenses, official or private documents, identification cards, and the like
- Copyright materials, or trademarks without the consent of the owner
- Postage stamps, and other negotiable instruments

This list is not inclusive, and no liability is assumed for either its completeness or accuracy. In case of doubt, contact your legal counsel.

Notice

Install your machine near a supervised area to prevent illegal duplication from being made.

Installation

- Do not place the unit in direct sunlight, in a cold draft, or near heating apparatus.
- Do not place the unit near apparatus which generate electronic or magnetic noise.
- Protect the unit from static electricity.
- Do not move the unit immediately from a cold place to a warm place. It may cause dew.

CD-ROM

- Do not write or stick paper on the front and/or back of CD-ROM.
- Do not touch the data side of the CD-ROM. When handling the CD-ROM, be careful not to leave fingerprints or otherwise damage the CD-ROM.
- Do not leave the CD-ROM where it is directly exposed to sunlight or near a heater for extended periods.
- Do not throw or bend the CD-ROM.

Roller Cleaning Paper

- Keep the roller cleaning paper out of reach of small children.
- Do not store the roller cleaning paper in direct sunlight or in a place with a temperature over 40 °C (104 °F).
- Only use the roller cleaning paper to clean the rollers and scanning glass.
- For details about the roller cleaning paper, please refer to the Material Safety Data Sheet (MSDS). Please ask your Panasonic sales company about obtaining the Material Safety Data Sheet.

KEEP AWAY FROM FIRE.

Security Notice

The management of documents and scanned data is the responsibility of the user. In particular, pay attention to the following points.







- Make sure you have the same number of pages for important documents both before and after scanning, and take care not to leave any pages in the scanner.
- Periodically back up important data.
- When having your computer or hard disk serviced, or when disposing of your computer or hard disk, completely erase any stored image data.

Others

- Make sure to remove paper clips and staples from documents before scanning. Failing to do so can damage the unit, document, or both.
- Do not use thinner, benzine, or cleaners containing abrasives or surfactants, for cleaning the outside of scanner.

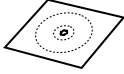
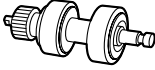
Check the Accessories

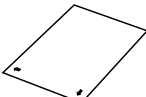
Check that all accessories are included before installing the unit. In the event that an item is missing, please contact your dealer.

Accessories	Name	Notes
	Power cord	Two power cords may be included. Use the power cord appropriate for where you use the unit.
	USB cable	—
	Software / Manual CD-ROM	Drivers, Applications, Utilities, Documents
	Double feed prevention roller	—
	Exit support sheet	—
	Shading paper	Use this paper when performing shading adjustment.
	Roller cleaning paper	—
	Quick Installation Guide	—

Note

- It is highly recommended to keep the original carton and all packing materials. They are necessary when repacking.

Main Unit

Front

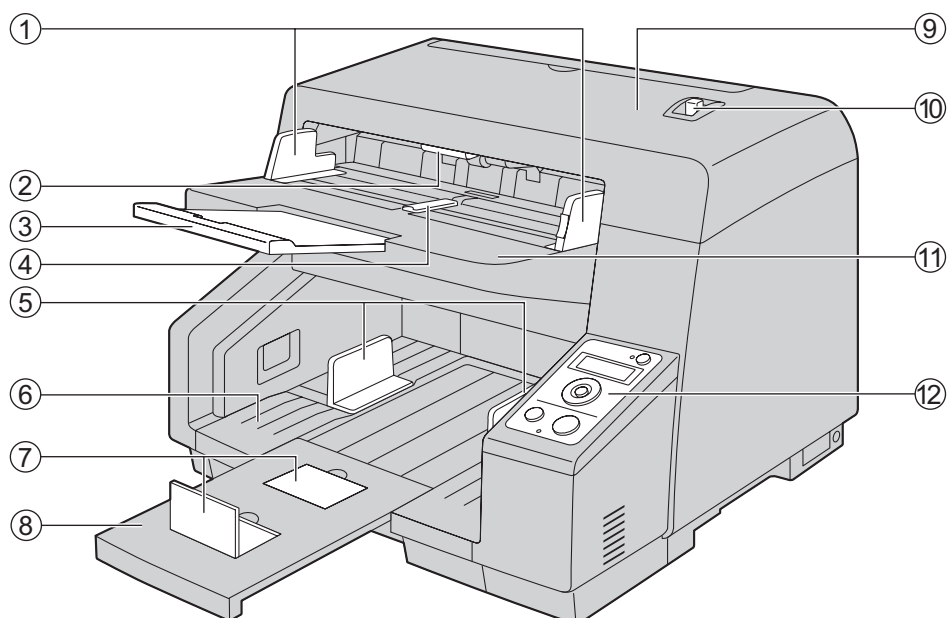

- ① Document guides
- ② ADF door release
- ③ Feed extension tray
- ④ Document guides selector
- ⑤ Exit guides
- ⑥ Exit tray
- ⑦ Exit stoppers
- ⑧ Exit extension tray
- ⑨ ADF door
- ⑩ Manual feed selector
Switches the scanning method between continuous scanning (Auto) and manual scanning (Manual).
- ⑪ Feed tray
- ⑫ Control panel
For details, refer to "Control Panel and LED Indicators" (page 13).

Rear

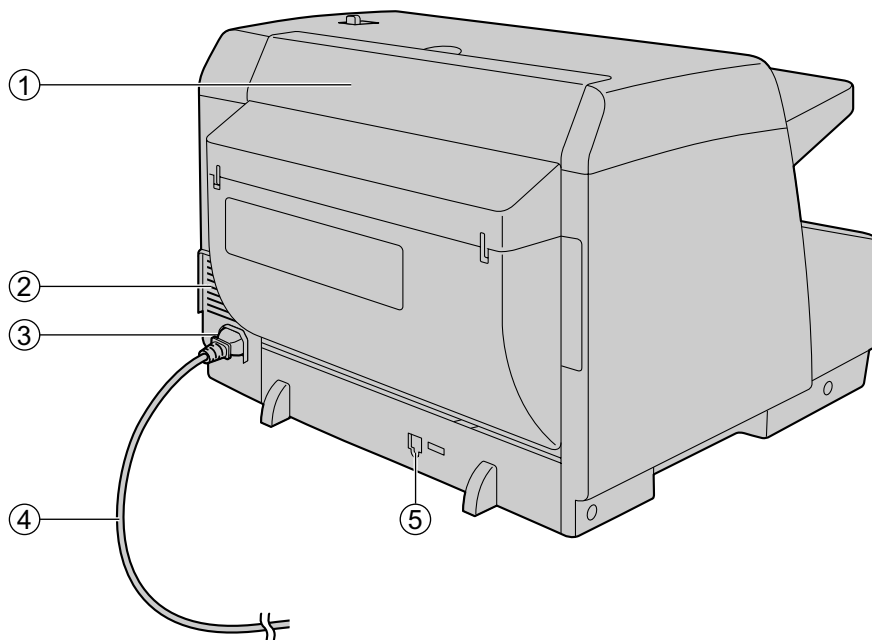

① **Imprinter door**

You open this door when installing an imprinter unit (sold separately) or ink cartridge. For details about installing an imprinter, refer to "Installing the Imprinter Unit and Ink Cartridge" (page 67).

② **Fan exhaust vent**

③ **AC inlet**

④ **Power cord**

Plugs may vary in shape depending on country/area.

⑤ **USB connector**

Control Panel and LED Indicators

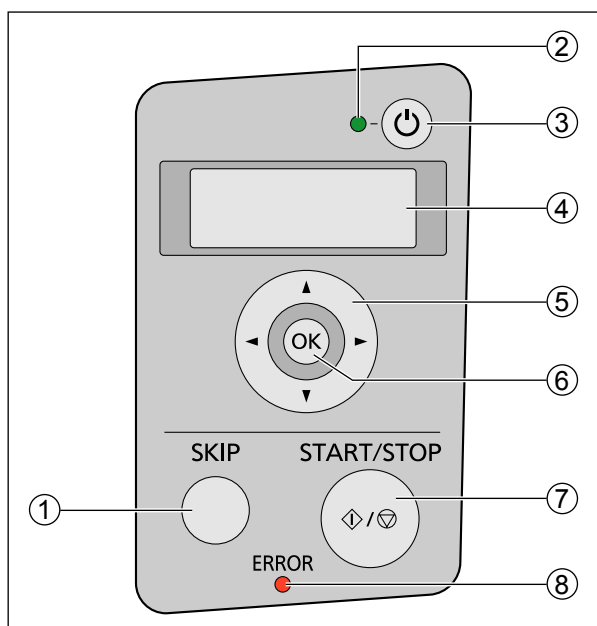

- ① **Skip button (SKIP)**
If you press this button after a double feed or a dog-eared document is detected and scanning has been paused, the document that was detected as a double feed or the dog-eared document will be scanned, and then ejected from the scanner. Scanning will continue after the document is scanned and ejected.
- ② **LED (Green)**
Shows the scanner's status.
- ③ **Power button (⏻)**
Press the power button for more than one second to turn the unit off.
- ④ **LCD (KV-S5076H only)**
If you are using a KV-S5076H with Image Capture Plus, you can perform push scan using the LCD. Registered jobs are displayed on the LCD. Use the cursor button and OK button to select a job. Also, error codes and messages corresponding to the scanner status are displayed on the LCD.
- ⑤ **Cursor button (KV-S5076H only)**
- ⑥ **OK button (OK) (KV-S5076H only)**
- ⑦ **Start/Stop button (START/STOP)**
 - If you set [Wait Key] for "Manual Feed Mode"^{*1} in your application software, pushing this button starts scanning.
 - During scanning, pushing this button stops scanning.
 - If you press this button after a double feed or a dog-eared document is detected and scanning has been paused, the document that was detected as a double feed or the dog-eared document will be ejected from the scanner without being scanned. Scanning will stop.
- ⑧ **LED (Red)**
Lights when an error occurs.

^{*1} For details about "Manual Feed Mode", refer to the Image Capture Plus, TWAIN, or ISIS help.

About LED

The status of the scanner is displayed by the LED (Green) (③) and the LED (Red) (④), as shown in the table below:

③ LED (Green)	④ LED (Red)	Status
OFF	OFF	Power OFF ¹
ON	OFF	Ready mode or Scanning
Blinking (Slow)	OFF	Sleep mode ²
OFF	ON	Error ³
Blinking (Fast)	OFF	Warming up
Blinking (Fast, 2 times consecutively)	OFF	Double Feed Skip mode
Blinking (Fast, 3 times consecutively)	OFF	Dog-ear Detection Skip mode

¹ If the power off feature in sleep mode is enabled, and if no operation is performed for a certain period of time, the scanner will be turned off automatically. Press the power button of the scanner to turn it on. You can enable/disable the power off feature, and change the time until the scanner turns off in User Utility.

² If no operation is performed for 15 minutes or longer, the scanner will enter sleep mode automatically to conserve energy. Press the Start/Stop button of the scanner to return to ready mode. The time until the scanner enters sleep mode can be changed in User Utility.

³ For details about the error, refer to "Error Messages (KV-S5076H only)" (page 77) or check in User Utility.

About the Installation Location

In order to ensure proper operation, install the unit maintaining the proper distances from surrounding objects, as shown in the following illustration.

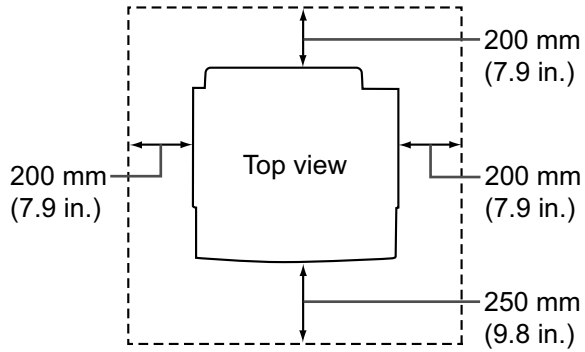

Notice

- Do not move the unit immediately from a cold place to a warm place. It may cause dew.

Note

- It is recommended to move this unit with two persons, and holding it by both side grips.
- The weight of this unit is approximately 24 kg (53 lb.) when packaged, or approximately 18 kg (39.5 lb.) by itself.

Installing the Unit

1. Remove all packing tape.
2. Push the ADF door release (①) upwards, and open the ADF door (②).

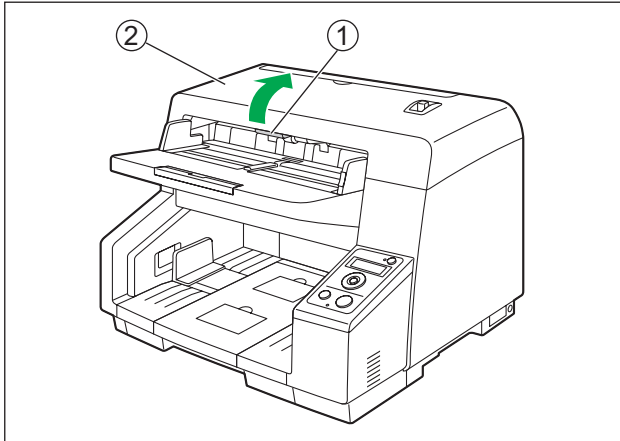

3. Use the indents (①) to pull the double feed prevention roller cover towards you to open it.

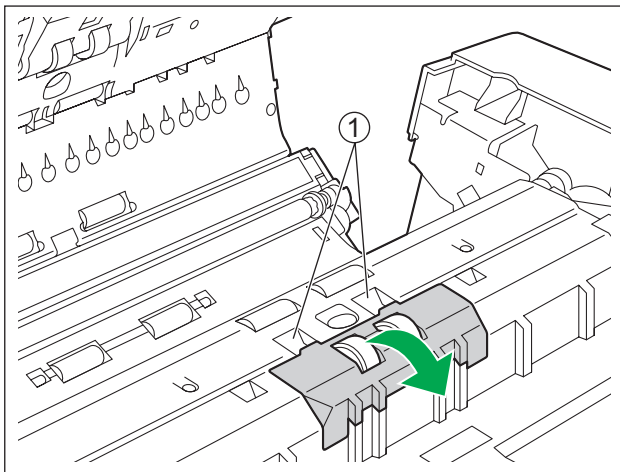

4. Install the double feed prevention roller.

- Align the shaft that is shaped as indicated by ① with the notch in the roller mount (②), and then insert the shaft in the notch. Push the shaft on the opposite side (③) until it clicks into place.

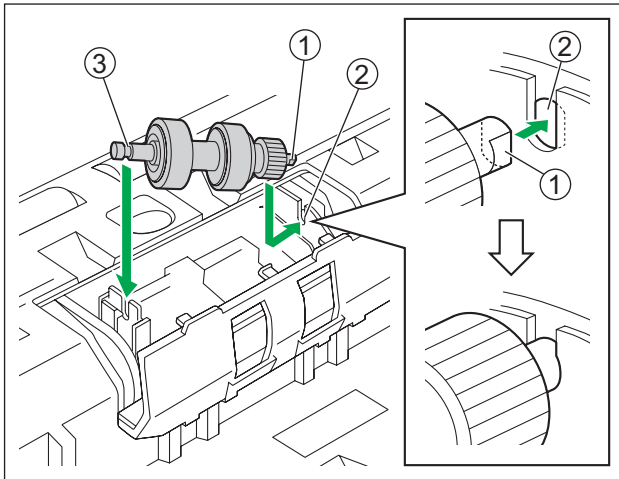
**Notice**

- After you install the double feed prevention roller, make sure that the shaft is inserted into the tab. If the roller is not installed correctly, it may cause double feeding or a paper jam.

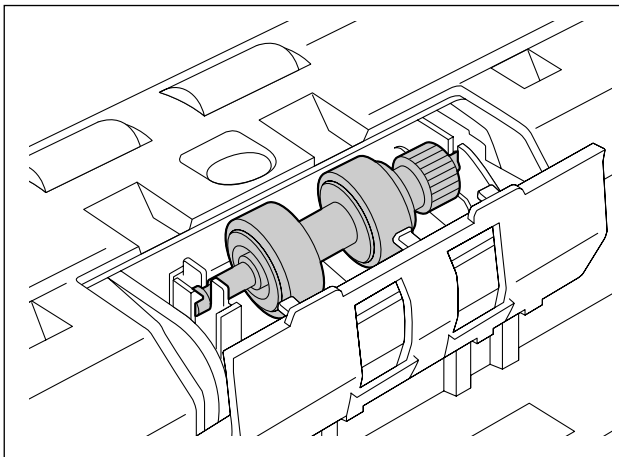

5. Push the double feed prevention roller cover until it clicks into place to close it.

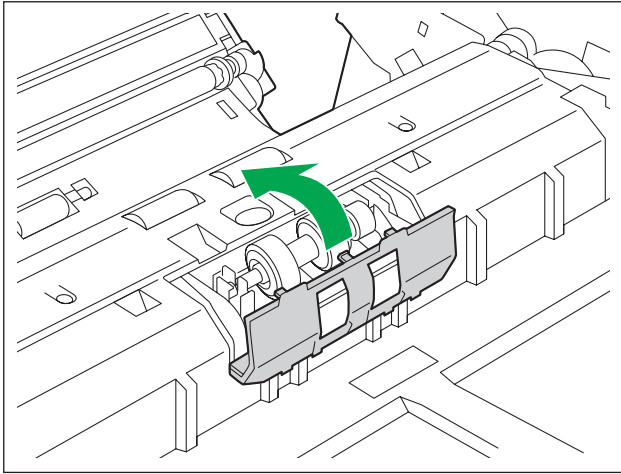

Notice

- Make sure that the double feed prevention roller cover does not stick up. If the double feed prevention roller cover is closed incompletely, damage or paper jams can occur.

6. Close the ADF door.
 - Push both sides of the ADF door down slowly until it clicks into place.

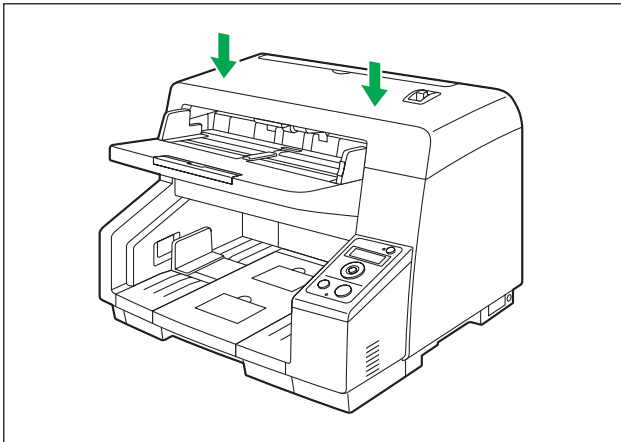

7. Connect the power cord and the USB cable to the scanner.

Notice

- Use only the power cord and the USB cable that are provided with the unit.
- When the unit is not used over an extended period of time, turn the unit off, and unplug the power cord. The unit consumes approximately 0.3 W of electricity even when the main unit is turned off.
- Do not turn ON the unit's power before installing the software.

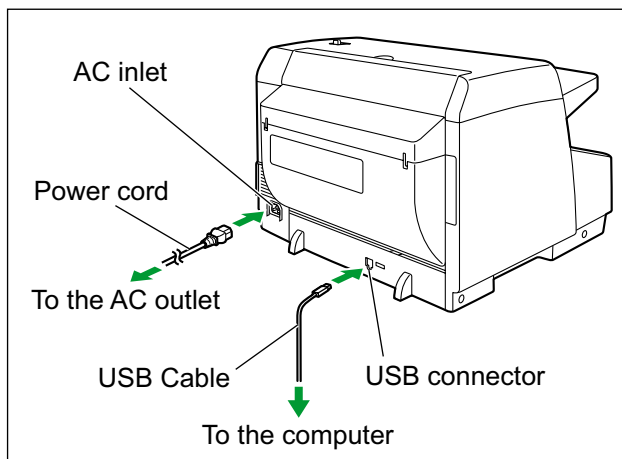

Installing the Software

The software on the enclosed Software / Manual CD-ROM can be installed on your computer. You can select from the 2 installation methods below, depending on your needs.

- a. **Complete:** Install all the drivers, applications, utilities and Operating Manual.
- b. **Custom:** Install one of the software or Operating Manual.

Note

- Normally, it is recommended to select [Complete].

Notice

- Make sure to log on as an administrator to install the software.
1. Check that the unit has been turned off.
 - Press the power button for more than one second to turn the unit off.
 2. Insert the Software / Manual CD-ROM into the CD/DVD drive on your computer.
 - If you have a feature called "Autorun" activated, the installation process will start automatically.
 - The setup window will appear.

Note

- If the AutoPlay dialog box is displayed, select [CDRun.exe].
 - If the setup window does not appear, double-click [CDRun.exe] in the Software / Manual CD-ROM.
3. Select your scanner model.
 4. Check the [Read me first] file.

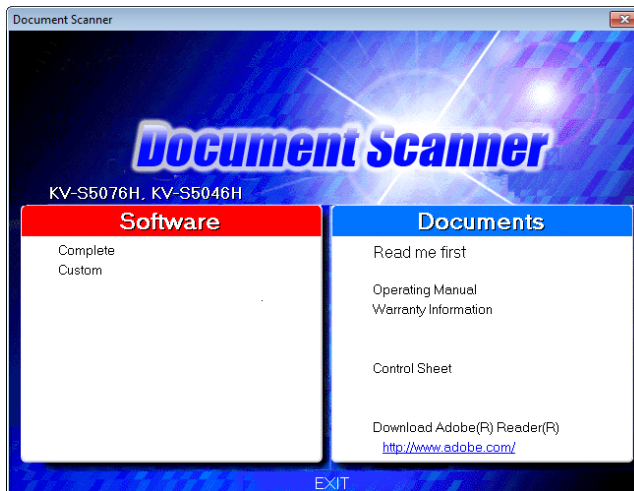

5. Select the desired installation methods from "Software" on the left side of the screen.
 - If you selected [Complete], continue to step 7.
 - If you selected [Custom], continue to step 6.

6. If you selected [Custom] for the installation type in step 5, select the item that you want to install.

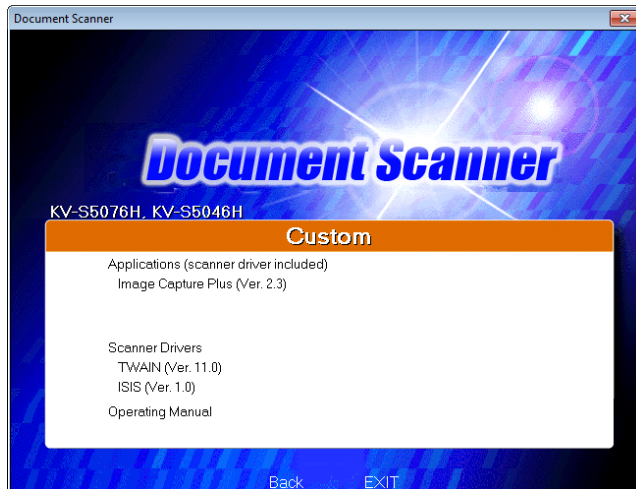

Note

- If you select TWAIN or ISIS, Image Capture Plus will also be installed.
7. Follow the instructions on the screen and complete the installation.
- Restart your computer if you are prompted to do so.
8. Press the power button (①) to turn ON the unit's power.

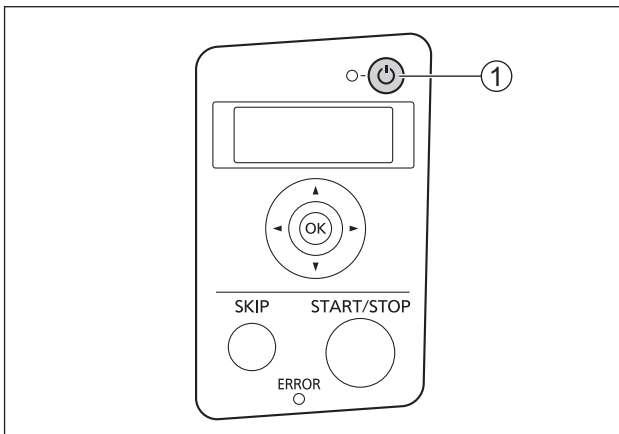

- The LED (Green) will flash and then turn on.
- If the hardware wizard appears, follow the on-screen instructions to complete installation.

Viewing Operating Manual and Help Installed

If the manuals and software that were included on the Software / Manual CD-ROM have been installed on your computer, you can use the following procedure to view the Operating Manual and the software's help.

To view the Operating Manual

1. Select [All Programs] → [Panasonic] → [Scanner Manuals].
2. Select the manual.
 - The manual will open.

Note

- In Windows 8, select the [Panasonic Document Scanner] section on the Apps screen.

To view the help

Note

- We recommend that you view the help using Internet Explorer® 6.0 or later for Windows.

For Image Capture Plus

1. Select [All Programs] → [Panasonic] → [Image Capture Plus] → [Image Capture Plus Help].

For User Utility or Scan Button Setting Tool

1. Select [All Programs] → [Panasonic] → [Scanner Tools].
2. Select that item's help.

Note

- In Windows 8, select the [Panasonic Document Scanner] section on the Apps screen.

For TWAIN or ISIS

1. Click the help button on any driver screen.

Preparing Documents

Notice

- Make sure to remove paper clips and staples from documents before scanning. Failing to do so can damage the unit, document, or both.

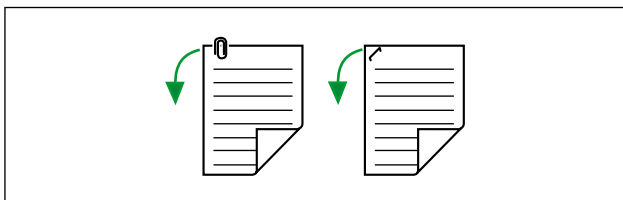

- Before feeding, ensure that the document is not creased or folded. If the document is creased or folded, a paper jam or damage to the document may occur.
- When scanning important documents, confirm that the number of scanned images matches the number of pages in the feed tray. Also, check the condition of the scanned documents.
- Remove documents from the exit tray after they have been scanned.

Acceptable Documents

Document size:

The acceptable document sizes for this unit are as follows.

- When feeding multiple sheets:
Landscape orientation: 48 – 307 mm (1.9 – 12.09 in.), portrait orientation: 70 – 432 mm (2.8 – 17 in.)
 - When feeding one sheet:
Landscape orientation: 48 – 307 mm (1.9 – 12.09 in.), portrait orientation: 70 – 2,540 mm (2.8 – 100 in.)^{*1}
- ^{*1} Using "Long Paper", you can scan long documents by splitting them into smaller parts. For details about "Long Paper", refer to the Image Capture Plus, TWAIN, or ISIS help.

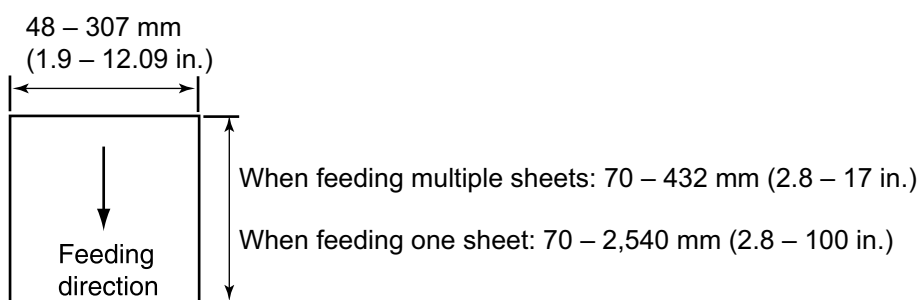

Paper thickness for feeding:

20 – 157 g/m² (5 – 42 lb.)

Feeding capacity:

For 80 g/m² (21 lb.) new paper, a maximum of 300 sheets can be placed on the feed tray with a combined thickness of 30 mm (1.18 in.) or less.

For documents less than 100 mm (3.94 in.) in length, the maximum is 150 sheets with a combined thickness of 15 mm (0.59 in.) or less.

Document types

<ul style="list-style-type: none"> • Plain paper • Bond paper • Newspaper • Carbonless copy paper 	<ul style="list-style-type: none"> • Recycled paper • OCR paper • Bank checks • Tracing paper
---	---

Recommended paper: Plain paper

Documents must also meet the following conditions

Curl	<p style="text-align: center;">Feeding direction ←</p>
Folding	<p style="text-align: center;">Feeding direction ←</p>

Unacceptable Documents

The following types of documents may not scan properly:

- Torn or frayed documents
- Curled, wrinkled or folded documents
- Carbon paper
- Thick or irregular documents such as envelopes, documents that are glued together, etc.
- Perforated or punched paper
- Non-rectangular or irregularly shaped paper
- Coated paper
- Photographs^{*1}
- Extremely smooth, shiny paper, or paper that is highly textured^{*1}

^{*1} Documents may become scratched or damaged, etc.

Do not scan the following types of paper:

- Documents out of specified size, thickness, and weight
- Thermal or photosensitive paper
- Cloths, metallic sheets, OHP sheets, plastic films, etc.
- Documents containing hard attachments such as metal or plastic (ex. clips or staples)
- Bound or glued documents
- Document with wet ink or cinnabar seal ink

Notes about documents for scanning

- Depending on the paper type, scanning results may be poor when you scan unacceptable documents, or even documents that should be acceptable.
If scanned images are skewed, paper jams occur, or double feeding occurs, try scanning again after doing the following:
 - Clean the rollers and sensors.
 - Reduce the number of sheets of paper loaded on the feed tray.
 - Change the orientation of documents placed in portrait orientation to landscape orientation, or vice versa.
 - In the scan settings, set "Feeding Speed" to [Slow].^{*1}
 - Scan the documents using manual scanning.
- When using stapled document detection, completely flatten any curling or creases on the rear end of the document, and then perform scanning. (KV-S5076H only)

^{*1} For details about configuring the scan settings, refer to the Image Capture Plus, TWAIN, or ISIS help.

Scanning Documents

1. Adjust the document guides (①) slightly larger than the actual size of the documents.

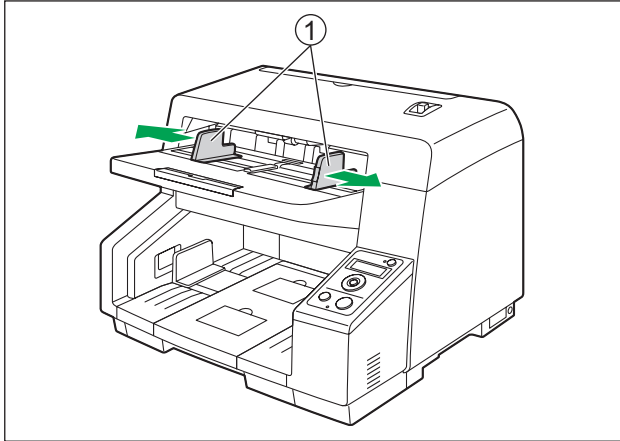

2. Fan the documents.
 - Documents that have been stapled together or stacked together (as in a file folder) will need to be separated.
 - ① Fan the stack of documents to separate all the edges.
 - ② Hold both ends and bend the documents as shown in the illustration.
 - ③ To flatten the documents, hold firmly and pull them apart as shown in the illustration.

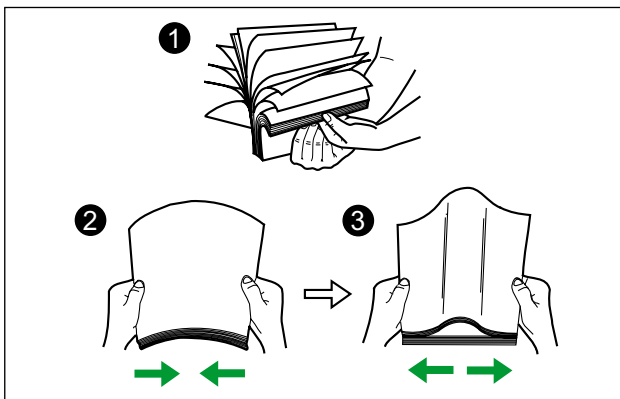

Repeat these steps as necessary.

3. Carefully align the documents.

4. Place the documents on the feed tray (①) with the side to be scanned facing up. Then push the documents in the direction of the arrow until they stop.

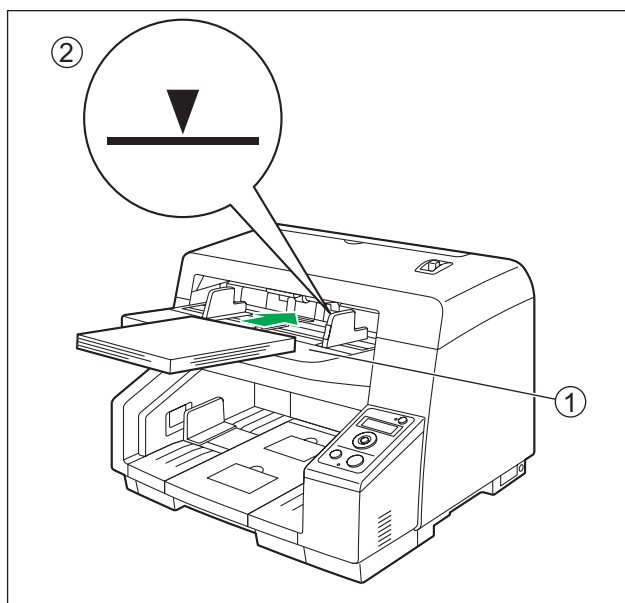

Notice

- The height of the documents should not exceed the limit mark (②) on the document guide. Exceeding the limit mark may cause a paper jam or skewing.

When scanning long sheets of paper

Pull out the feed extension tray (③) from the feed tray.

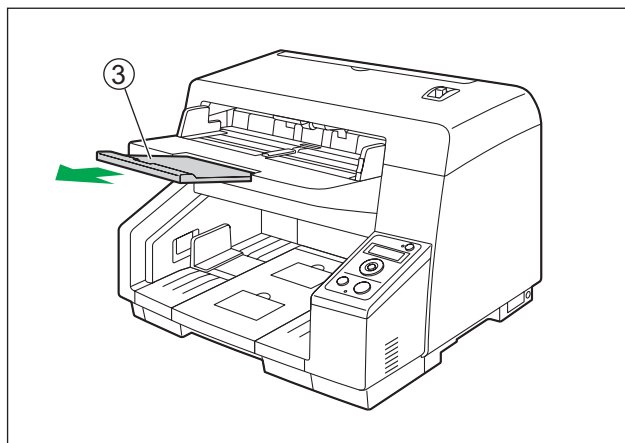

5. Slide the document guides (①) to match the width of the document to be scanned.

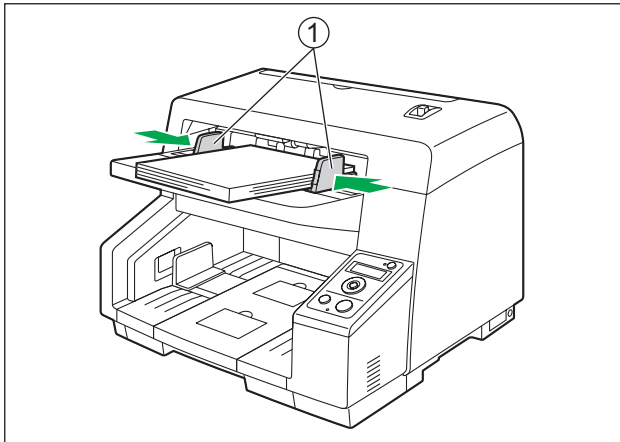

- When scanning documents with pages of different sizes at one time, see "When Scanning Documents with Pages of Different Sizes at One Time" (page 32).
- To secure the document guides (①), lower the document guide lock (②).

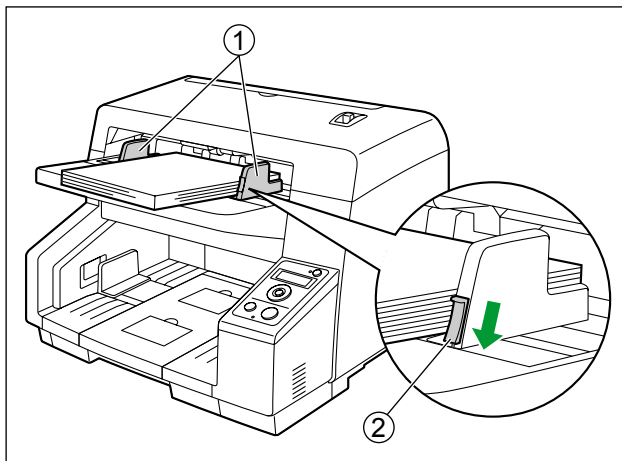

6. Raise either the front side (①) or back side (②) exit stopper according to the size of the documents.

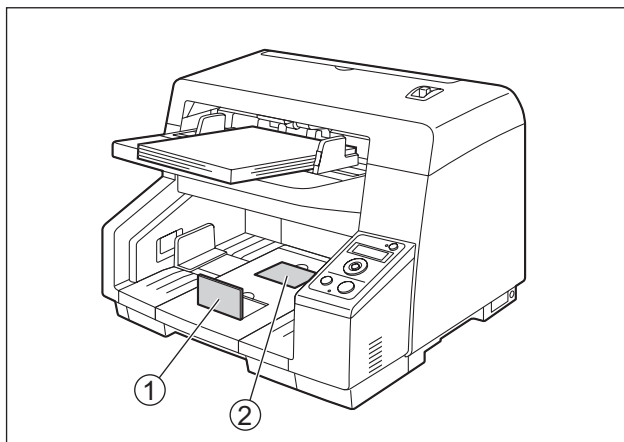

7. Adjust the exit extension tray (①) to match the size of the documents.

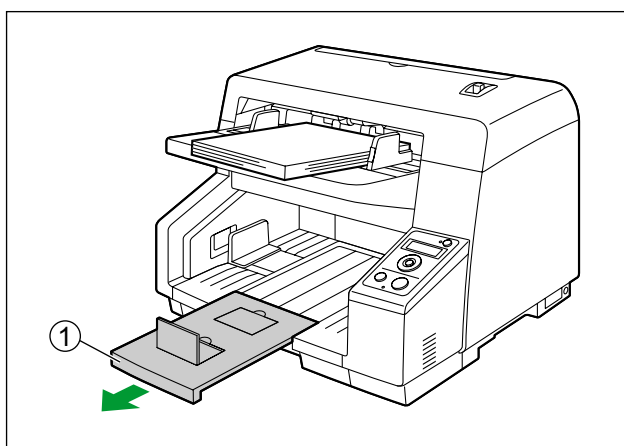

8. Adjust the exit guides (①) to be slightly larger than the actual size of the documents.

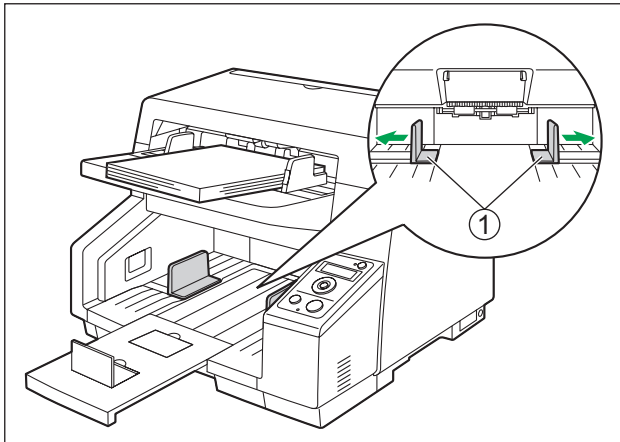

Note

- Adjust the exit guides to be larger than the actual size of the documents to avoid paper jams.
- If exiting sheets become out of order on the exit tray, attach the included exit support sheet (②) into the holes (③) above the exit slot.

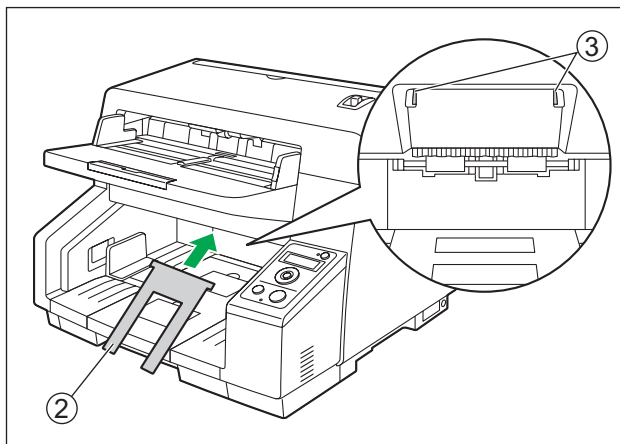

9. Open your scanning application and scan the documents.
- For details about the application, refer to the help of each application.
 - You can also start up applications automatically to scan documents (Single Touch Scan). For details about Single Touch Scan settings, see "Starting Up Scanner Applications Automatically" (page 39).
 - You can also scan documents by selecting the pre-registered settings on the LCD. (KV-S5076H only)

When Scanning Documents Manually

You can select either continuous scanning (Auto) or manual scanning (Manual) by using the manual feed selector.

Continuous scanning (Auto)

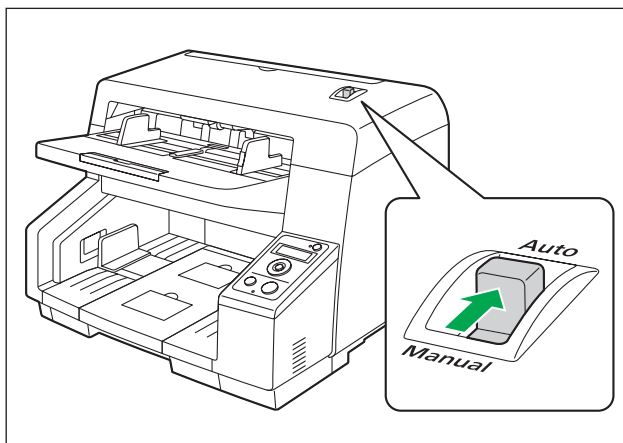

Manual scanning (Manual)

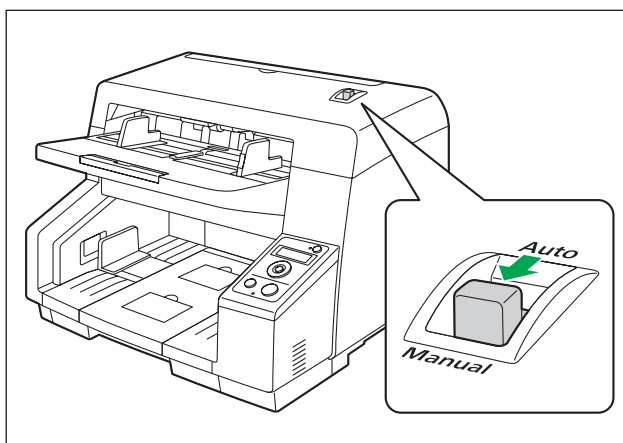

Notice

- When scanning a document manually (Manual), feed the document 1 sheet at a time.
- When scanning important documents or bound documents, feed them manually.

Note

- When scanning a document manually (Manual), the double feed detection function is disabled.

When Scanning Documents with Pages of Different Sizes at One Time

When scanning documents with pages of different sizes at one time, please note the following.

- Align the document pages along one side.
 - Align the document position so that the center of the smallest sheet will be fed to the center of the paper feed roller, and adjust the document guides accordingly.
 - Exiting sheets may become out of order on the exit tray. Documents may need to be reordered after they are scanned.
1. Slide the document guides selector in the direction shown in the illustration until the ◀ (①) and ● (②) marks are aligned.
 - The left and right document guides can be moved separately.

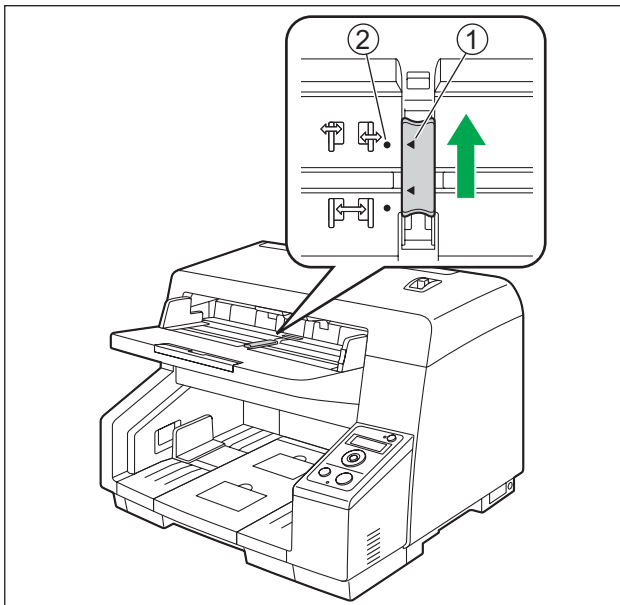

2. Completely spread apart the document guides (①).

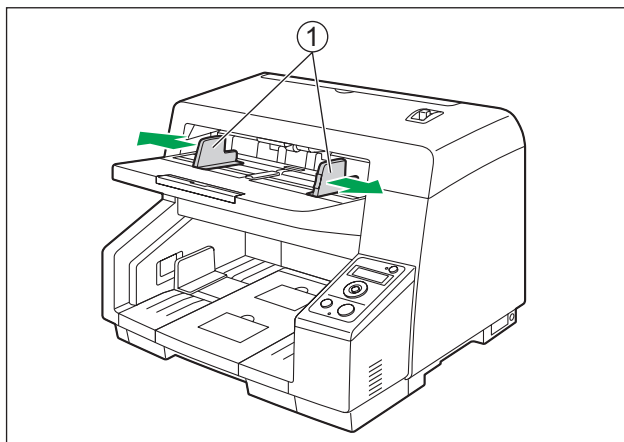

3. Align the documents sheet by sheet at one corner.
Align the documents sheet by sheet at one corner as shown below. Documents that stick together, are not aligned correctly at one corner, or are at an angle cannot be fed correctly.

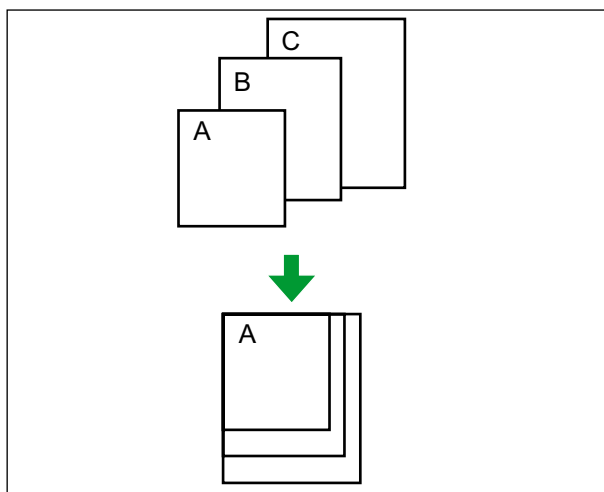

Operation

4. Place the documents on the feed tray (①) with the scanning side facing up.
 - Align the document position so that the center of the smallest sheet will be fed to the center of the paper feed roller (②). If the document is not properly aligned, the pages will not be fed correctly.

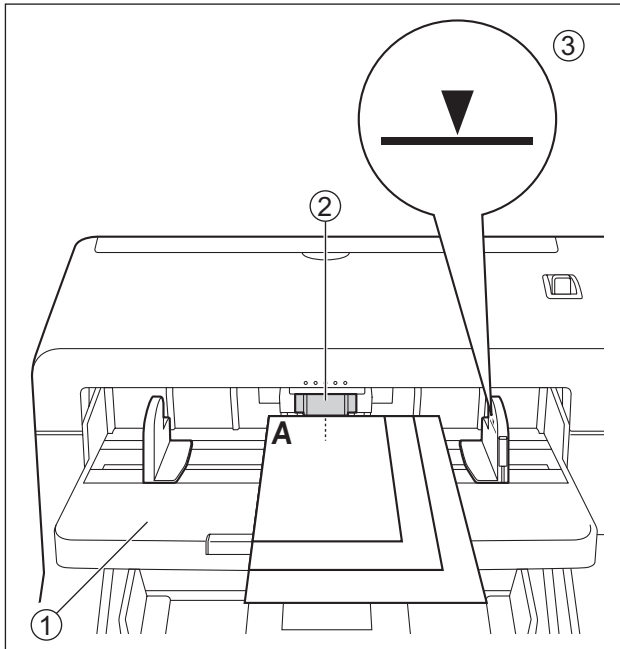

Notice

- The height of the documents should not exceed the limit mark (③) on the document guide. Exceeding the limit mark may cause a paper jam or skewing.
- Depending on the types of paper, the document may not be fed smoothly. In such case, reduce the number of sheets of the document.

When scanning long sheets of paper

Pull out the feed extension tray (④) from the feed tray.

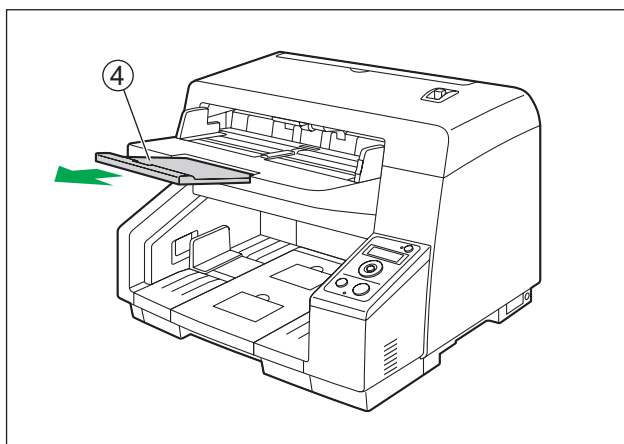

5. Adjust the left and right document guides (①) to the width of the documents.

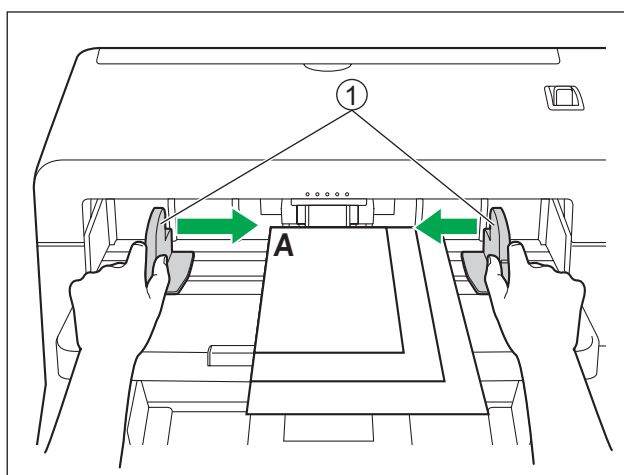

6. Remove the document, and then slide the document guides selector in the direction shown in the illustration until the ◀ (①) and ● (②) marks are aligned.

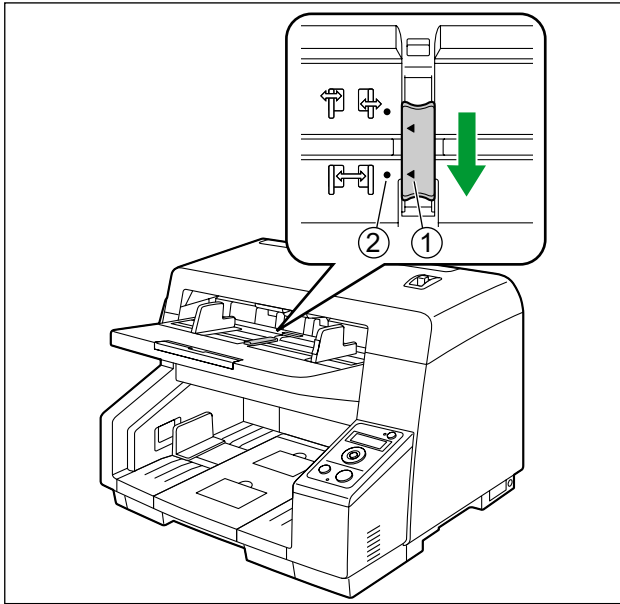

7. Place the document on the feed tray again and adjust the document guide according to the size of the document to be scanned.

Notice

- Make sure to align the document pages along one side.
- Make sure that the center of the smallest sheet of the document will be fed to the center of the paper slot.
- To secure the document guides, lower the document guide lock.

Adjusting the left and right document guides to their original position

1. Slide the document guides selector in the direction shown in the illustration until the ◀ (①) and ● (②) marks are aligned.

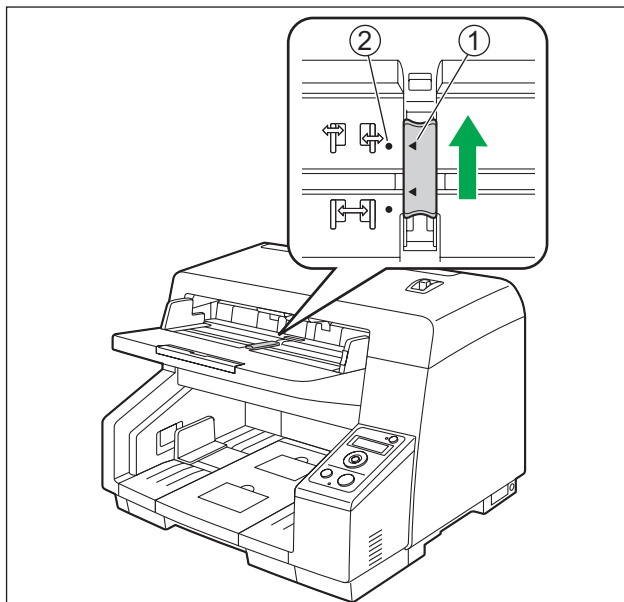

2. Completely spread apart the document guides.
3. Slide the document guides selector in the direction shown in the illustration until the ◀ (①) and ● (②) marks are aligned.

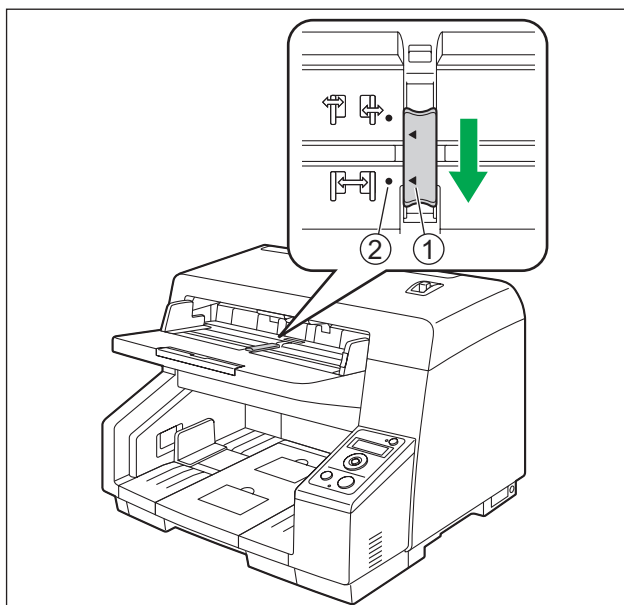

When Changing the Scanned Data Background Color

Using the software, you can switch the background color of scanned images between white and black. For details, refer to the Image Capture Plus, TWAIN, or ISIS help.

Starting Up Scanner Applications Automatically

You can configure settings so that the application starts up automatically by "placing a document on the unit's feed tray" ("Touch Free Scanning") or by "Single Touch Scanning".

Note

- If you are using a KV-S5076H, you can perform push scan using the LCD (page 41).
- If you are using a KV-S5046H, press the Start/Stop button to perform Single Touch Scanning.

Setting the application to start up

Set whether an application will automatically start up and select under which conditions it will start up in the Scan Button Setting Tool.

1. Double click the  icon in the notification area of the task bar to open the Scan Button Setting Tool.
 - In Windows 8, open the Scan Button Setting Tool on the Desktop screen.
2. Select Single Touch Scanning or Touch Free Scanning for the condition to automatically start up the application.
3. Select the application to start up.

Note

- The set application is enabled for both "Touch Free Scanning" and "Single Touch Scanning".
- For details about the Scan Button Setting Tool, refer to the Scan Button Setting Tool help.

Setting the scanning conditions

Scanning conditions are set on the setting screen of each application. For details about the setting screen of each application, refer to the manual or help for that application.

Note

- If you are using a KV-S5076H, press the OK button for more than 2 seconds to open the application setting screen.
- If you are using a KV-S5046H, press the Start/Stop button for more than 2 seconds to open the application setting screen.
- If the unit is in sleep mode, press the Start/Stop button to return to ready mode first.

Checking events

Check the following if an application does not start up after being set.

1. Display the Scan properties screen.
 - If you are using Windows 8 / Windows 7:
[Control Panel] → [View devices and printers], right-click the scanner icon, and display the [Scan properties] screen.
 - If you are using Windows Vista:
[Control Panel] → [Scanners and Cameras], select the scanner icon, and then click the Properties button.
 - If you are using Windows XP:
[Control Panel] → [Scanners and Cameras], right-click the scanner icon, and display the Properties screen.
2. Click the [Events] tab.
3. Check that Scan Button Setting Tool is selected as the program to start for each event.
 - If an application other than Scan Button Setting Tool is selected, change the application to Scan Button Setting Tool.
4. Click [OK].
5. Restart the computer.

Performing push scan using the LCD (KV-S5076H only)

If you are using a KV-S5076H with Image Capture Plus, you can perform push scan using the LCD. Registered jobs are displayed on the LCD. Use the cursor button (①) and OK button (②) to select a job.

Note

- Register jobs in advance. For details about registering jobs, refer to the Image Capture Plus help.
- The group name is displayed on the first line, and the job name is displayed on the second line of the LCD.

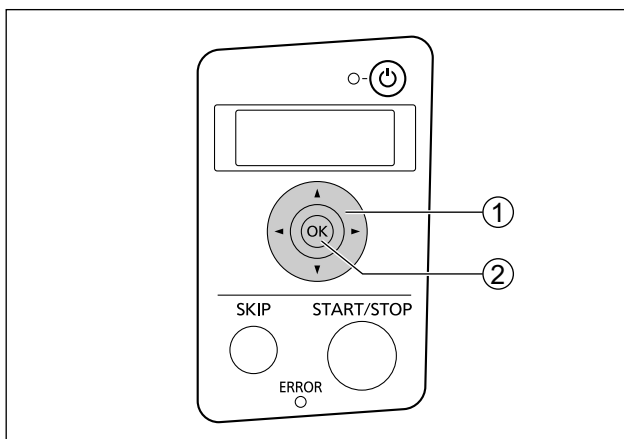

1. Place the documents on the feed tray with the side to be scanned facing up.
2. Use ◀ or ▶ of the cursor button (①) to select a group.
3. Use ▲ or ▼ of the cursor button (①) to select a job.
4. Press the OK button (②) to start scanning.

Using Control Sheets

Placing a control sheet in the middle of documents lets you change the scanning conditions for pages scanned after the control sheet. Also, you can change the folder used to save the scan data of documents scanned after the control sheet.

- Print out control sheets from the included CD-ROM.

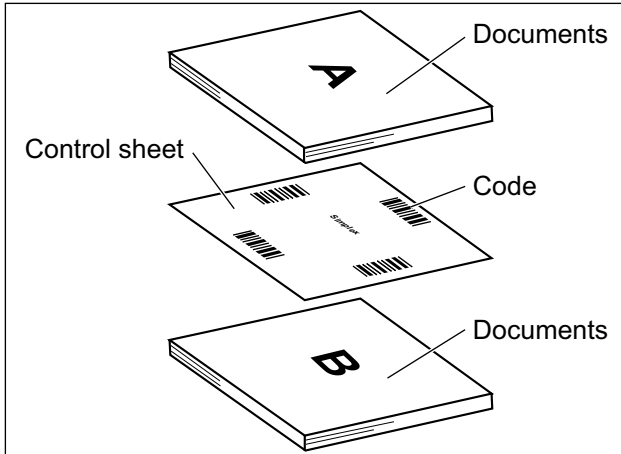

Control sheet functions

Simplex, Duplex, Binary, 256 level gray, Color, Dynamic Threshold, Dither, Error diffusion, Function #1–#9, Separation Sheet

- For details about control sheets, refer to "Detect Control Sheet" in the Image Capture Plus, TWAIN, or ISIS help.
- For details about separation sheets, refer to "Detect Separation Sheet" in the Image Capture Plus, TWAIN, or ISIS help.

About Printing Control Sheets

- Print the control sheet at the specified size; do not enlarge or reduce the size.
- When printing the control sheet, make sure that the pattern is 25 mm (1 in.) from the top of the page and centered horizontally.

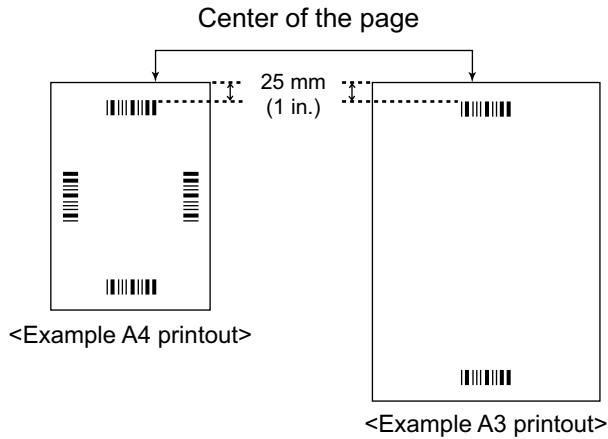

- Use the control sheet that is the same size as the document you are scanning.
- Be careful not to get the control sheet dirty. Do not fold or crease the control sheet. Scanning will not be performed properly.
- For details about control sheets, refer to "Detect Control Sheet" in the Image Capture Plus, TWAIN, or ISIS help.

Printing control sheets

Note

- In order to print control sheets, Adobe Reader must be installed on your computer.
- Refer to the instruction manual for your printer for details about changing print settings.

1. Insert the included CD-ROM into the CD/DVD driver on your computer.
 - If you have a feature called "Autorun" activated, the installation process will start automatically.
 - The setup window will appear.

Note

- If the AutoPlay dialog box is displayed, select [CDRun.exe].
- If the setup window does not appear, double-click [CDRun.exe] in the Software / Manual CD-ROM.

2. Select your scanner.
3. Select [Control Sheet] from "Documents" on the right side of the screen.
4. Print the control sheets at the same size as your document.

Clearing Paper Jams

Torn paper, thin paper or paper that is creased on the top edge may cause paper jams. If a paper jam occurs, remove the jammed sheet according to the following procedure.

CAUTION

- Do not touch the conveyor immediately after continuous scanning. This area becomes very hot and can cause burns. Wait until the conveyor's temperature decreases.

1. Push the ADF door release (①) upwards, and open the ADF door (②).

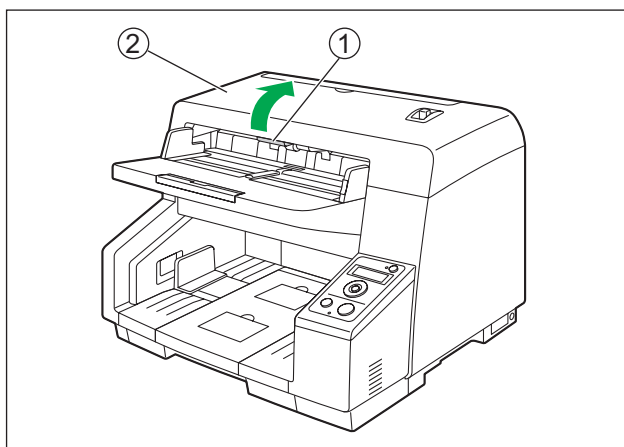

Clearing Paper Jams

2. Remove the jammed sheet of paper.

When a paper jam occurs inside the scanner:

Remove the jammed sheet of paper from the inside of the ADF door.

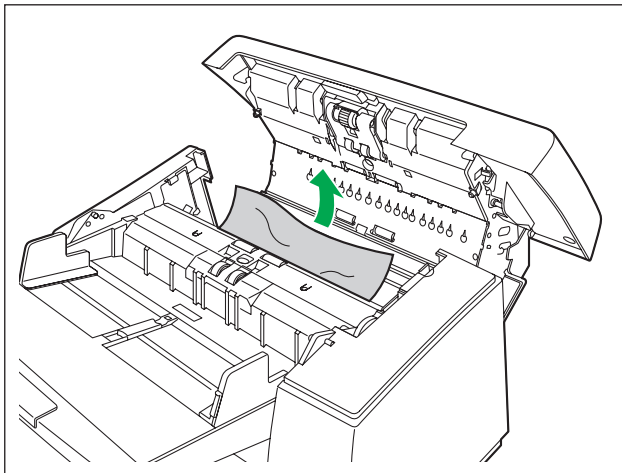

When a paper jam occurs at the exit slot:

Pull the jammed paper from the exit slot (1) towards the front.

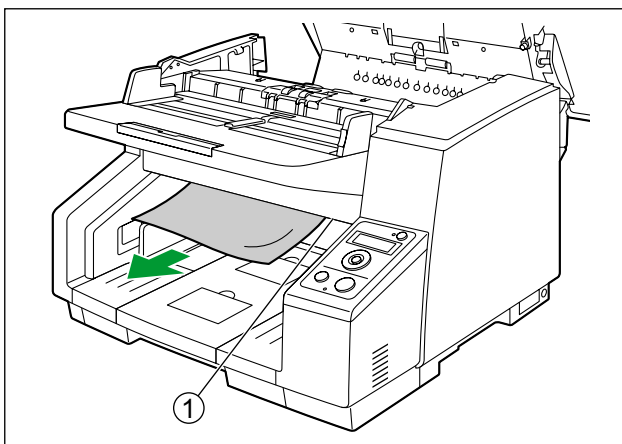

3. Close the ADF door.
 - Push both sides of the ADF door down slowly until it clicks into place.

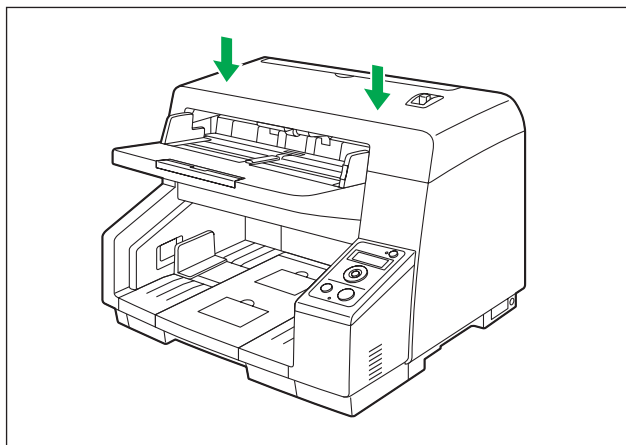

Cleaning the Outside of the Scanner

Notice

- Do not use commercially available cleaners, detergent, thinner, or benzine. (Doing so may cause deformation, discoloration or damage.)
- Clean the scanner at least once a month.

1. Press and hold the power button for one second or more to turn off the unit's power.
2. Clean the outside of the scanner with a soft, slightly damp cloth.
 - The document feeder (①) and exit slot (②) get dirty easily. Make sure to clean them.

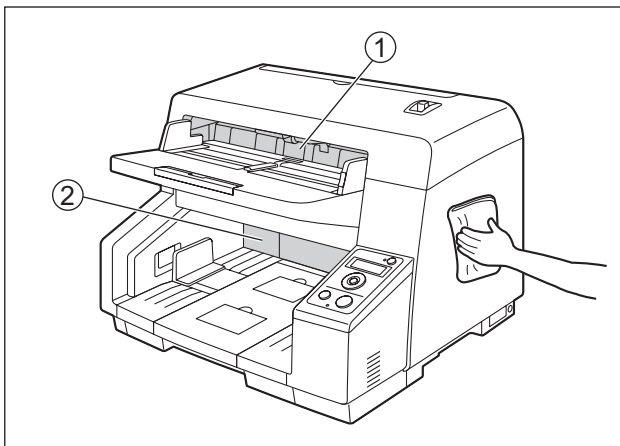

3. Remove dirt and dust from the fan exhaust vent (①) with a brush.

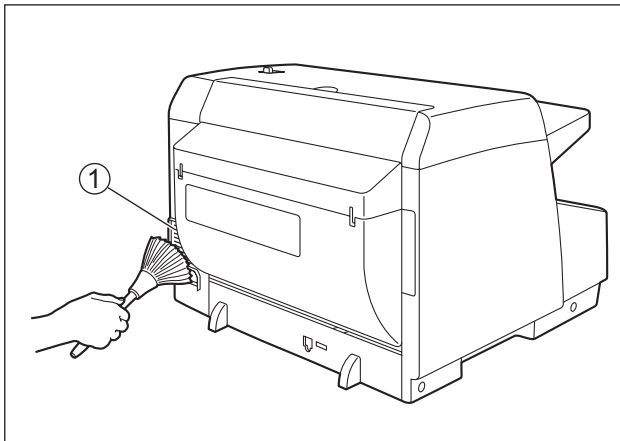

4. Press the power button to turn on the unit's power.

Cleaning the Inside of the Scanner

CAUTION

- Do not touch the conveyor immediately after continuous scanning. This area becomes very hot and can cause burns. Wait until the conveyor's temperature decreases.

Note

- Clean the inside of the scanner when approximately 20,000 sheets have been scanned. The time for cleaning may differ depending on documents you scan. To maintain proper scanning, clean the scanner parts frequently.
- Clean the rollers and sensors if paper jamming or double feeding occurs frequently.
- If double feed detection does not function properly, clean the double feed detectors.
- Clean the scanning glass when black or white lines appear on the scanned images.

About the roller cleaning paper

Using a pair of scissors, open the bag along the dotted line (①), and take out the roller cleaning paper.

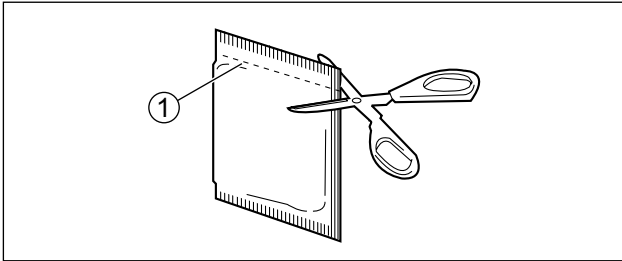

Notice

- Keep the roller cleaning paper out of reach of small children.
- Do not store the roller cleaning paper in direct sunlight or in a place with temperature over 40 °C (104 °F).
- Only use the roller cleaning paper to clean the rollers and scanning glass.
- For details about the roller cleaning paper, please refer to the Material Safety Data Sheet (MSDS). Please ask your Panasonic sales company about obtaining the Material Safety Data Sheet.

Note

- If the bag is left opened for a long period of time before using it, the alcohol will evaporate. Please use the roller cleaning paper immediately after opening the bag.
- To purchase the roller cleaning paper (KV-SS03), please contact your dealer, or call our Supplies and Accessories department at 1-800-726-2797 (U.S.A. only).

1. Prepare the following cleaning supplies.
 - **Soft and dry cloth**
Used to clean the conveyor.
 - **Thin cotton swab**
Used to clean the ion outlets and sensors.
 - **Roller cleaning paper (KV-SS03)**
Used to clean the rollers, scanning backgrounds, and scanning glasses.
Use of the roller cleaning paper is recommended. If you do not have the roller cleaning paper, use a soft cloth with a small amount of isopropyl alcohol or water.
Do not use commercially available cleaners, detergent, thinner, or benzene. (Doing so may cause deformation, discoloration or damage.)
2. Press and hold the power button for one second or more to turn off the unit's power.
3. Push the ADF door release (①) upwards, and open the ADF door (②).

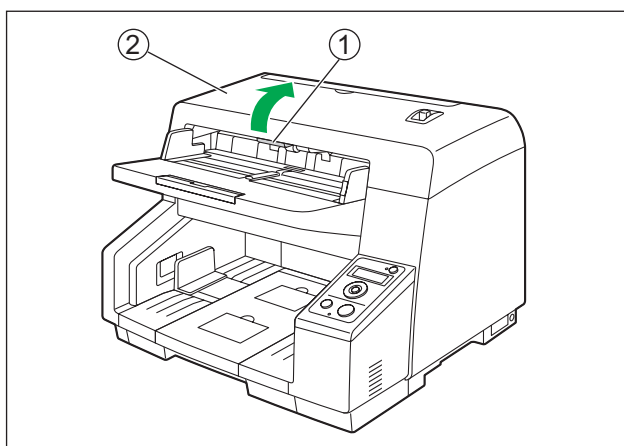

4. Clean the conveyor, sensors, rollers, scanning backgrounds, and scanning glasses.
 - Clean the parts in the following order: conveyor, ion outlets and sensors, rollers, scanning backgrounds, scanning glasses.
 - For details about cleaning, refer to the following:
 - "Cleaning the Conveyor" (page 53)
 - "Cleaning the Ion Outlets and Sensors" (page 54)
 - "Cleaning the Rollers" (page 56)
 - "Cleaning the Scanning Backgrounds" (page 58)
 - "Cleaning the Scanning Glasses" (page 59)

5. Close the ADF door.
 - After cleaning, push both sides of the ADF door down slowly until it clicks into place.

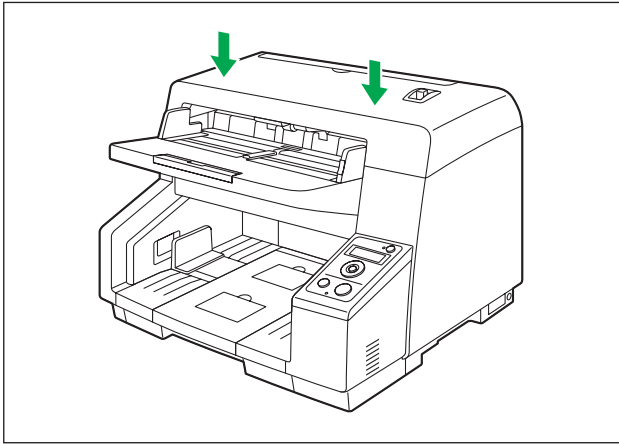

6. Press the power button to turn on the unit's power.

Notice

- If roller cleaning notifications via the After Clean Roller Counter are enabled, after turning on the unit's power, reset the After Clean Roller Counter in User Utility to 0. For details, refer to the User Utility help.

Cleaning the Conveyor

1. With a soft and dry cloth, wipe off any dirt on the conveyor (①).

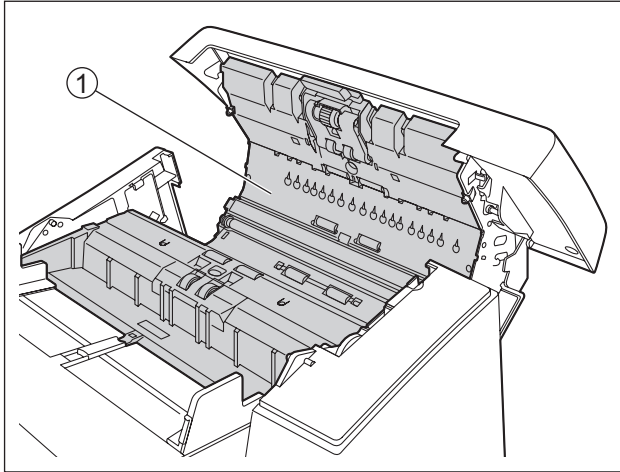

2. With a soft and dry cloth, wipe off any dirt on the self-cleaning brushes (③, ④) of the reference plates (①, ②).
 - Push ⑤ and ⑥ in the direction indicated by the arrow to rotate the reference plate on the ADF door side so that you can clean the brush. In the same way, push ⑦ and ⑧ in the direction indicated by the arrow to rotate the reference plate on the main unit side to clean the brush.

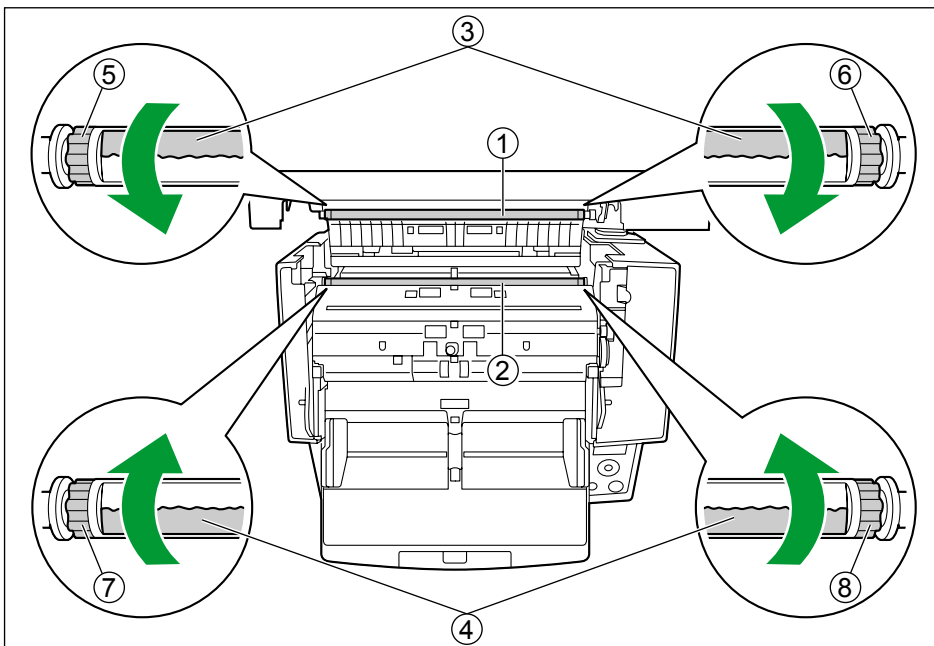

Cleaning the Ion Outlets and Sensors

1. Remove dust from the ion outlets (①) with a cotton swab.
 - With a thin cotton swab, remove dust from the ion outlets, and then wipe the center of the inner parts approximately 5 times.

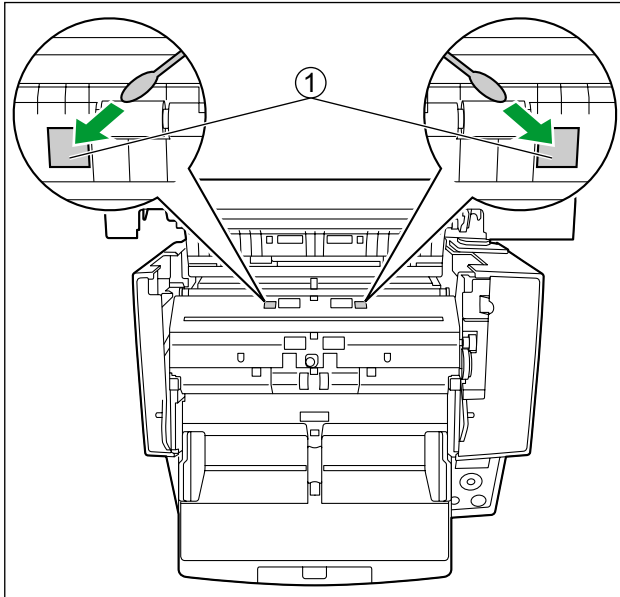

Notice

- Do not apply too much pressure on the parts.

2. Remove dust from the sensors (①, ②, ③, ④, ⑤, ⑥) and reflectors (⑦) with a cotton swab.

Location of Sensors

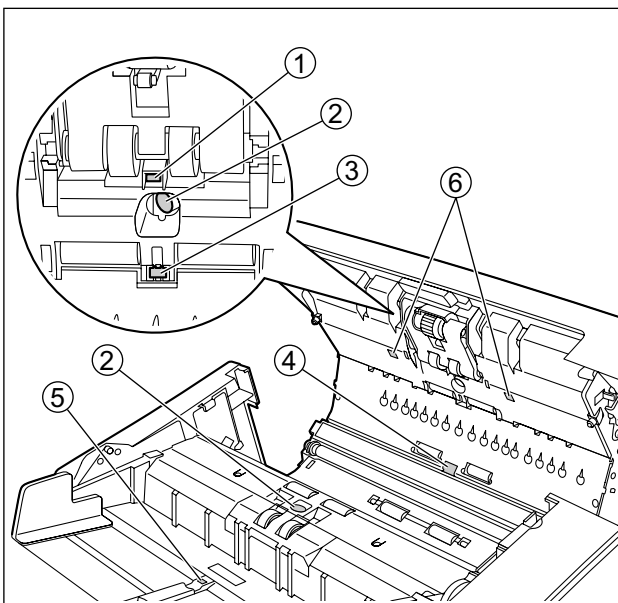

- ① Waiting sensor
- ② Double feed detector
- ③ Slip detect sensor
- ④ Starting sensor
- ⑤ Paper sensor
- ⑥ Skew sensor

Location of Reflectors

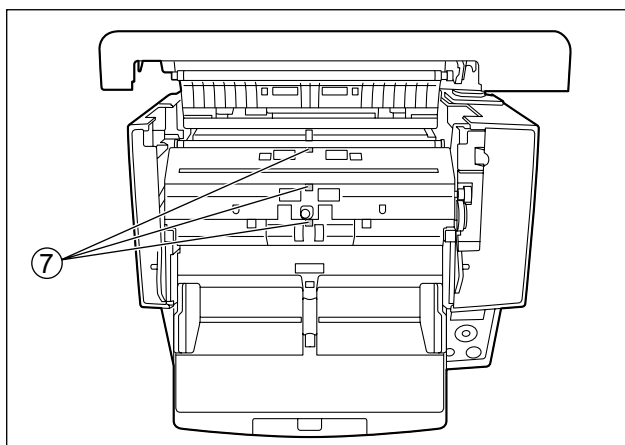

⑦ Reflectors

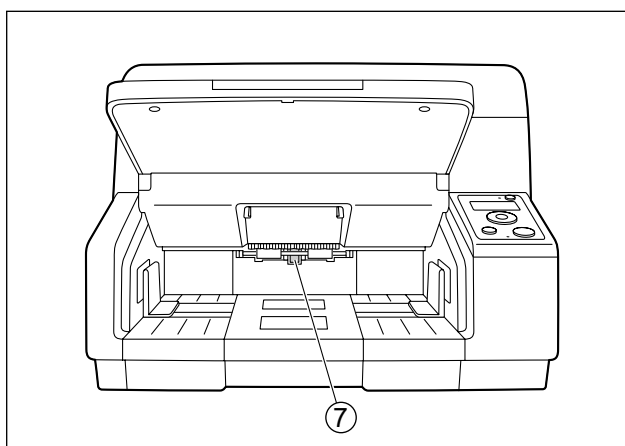

Cleaning the Rollers

1. Use the roller cleaning paper (page 50) to remove the dirt from the surfaces of all rollers.

Direction to wipe rollers

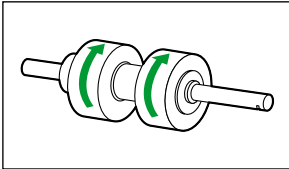

Double feed prevention roller, Separation roller

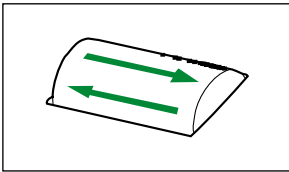

Other rollers

Notice

- After removing the double feed prevention roller, gently wipe dirt from the surface of the roller in the direction indicated by the arrows in the illustration. If you wipe too hard, you may damage or misalign the roller.
For instructions on how to remove the double feed prevention roller, see "Replacing the Rollers" (page 61).
- Wipe dirt off of the other rollers in the directions indicated by the arrows in the illustration. Use your finger to rotate the roller and wipe dirt off of the entire surface of the roller. If the roller rotates when wiping it, gently hold it in place with your finger.

Location of Rollers

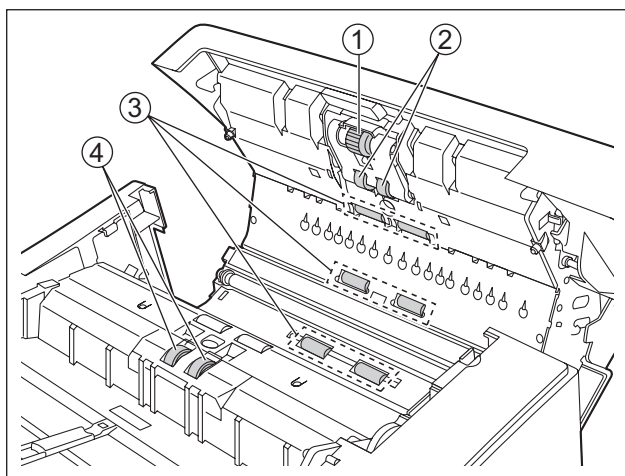

- ① Paper feed roller
- ② Separation roller
- ③ Free rollers
- ④ Double feed prevention roller

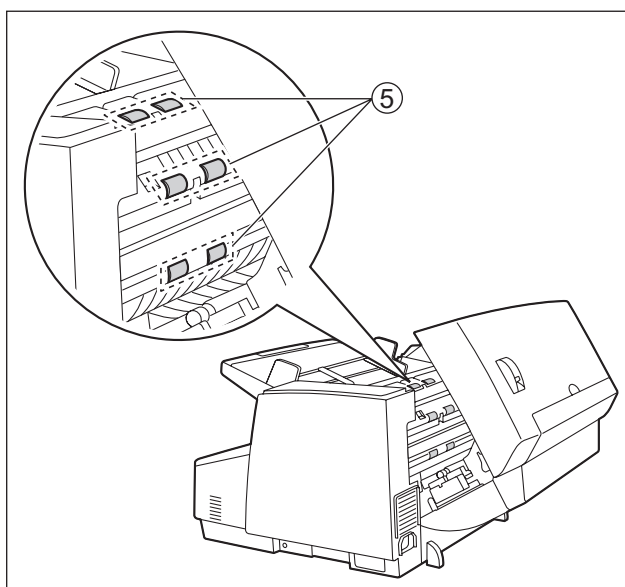

- ⑤ Drive rollers

Cleaning the Scanning Backgrounds

1. Wipe the scanning backgrounds (③, ④) on each reference plate (①, ②) with the roller cleaning paper (page 50).
 - Push ⑤ and ⑥ in the direction indicated by the arrow to rotate the reference plate on the ADF door side. Clean both the white and black backgrounds. In the same way, push ⑦ and ⑧ in the direction indicated by the arrow to rotate the reference plate on the main unit side to clean the white and black backgrounds.

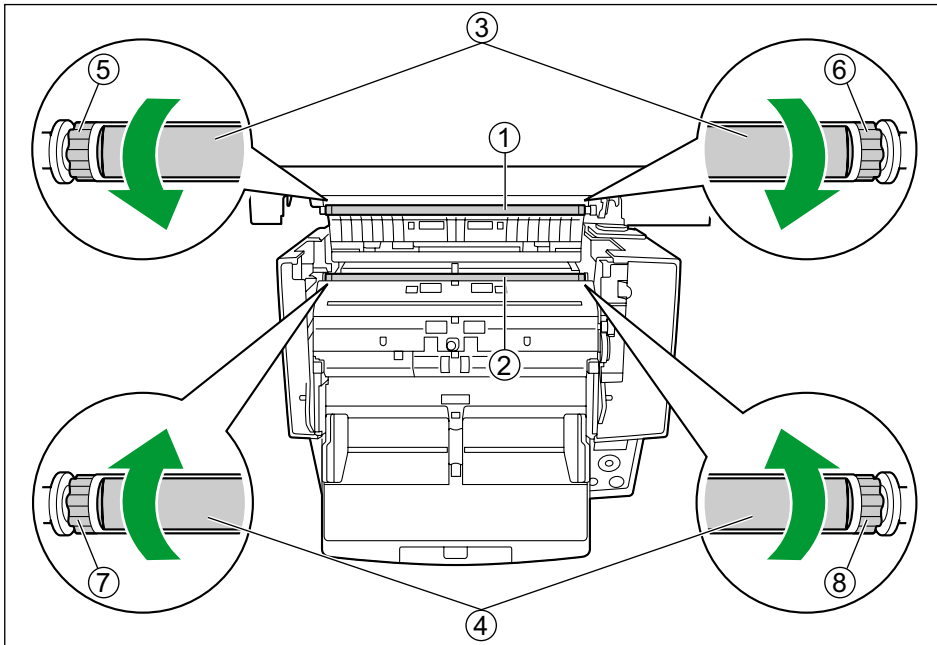

Cleaning the Scanning Glasses

1. Wipe the scanning glasses (①, ②) with the roller cleaning paper (page 50).

Location of Scanning Glasses

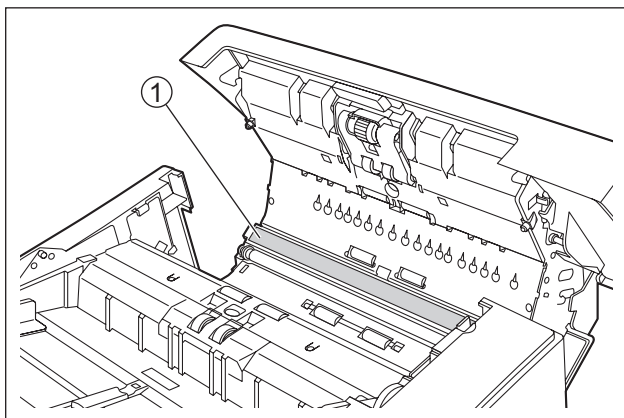

- ① Scanning glass (F)

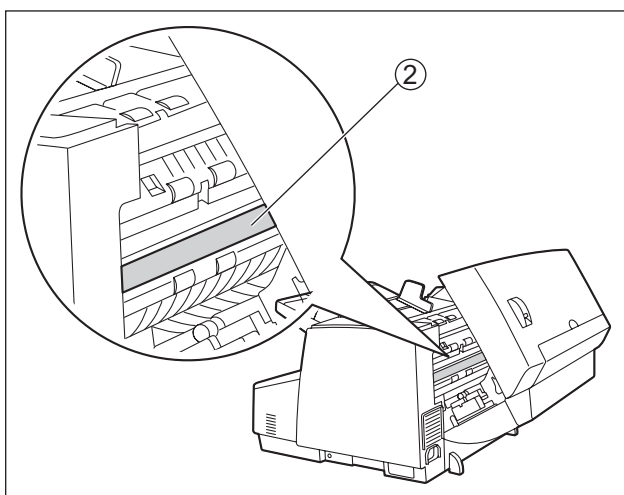

- ② Scanning glass (B)

Consumables and Optional Accessories

	Part Name	Part Number	Notes
Consumables	Roller exchange kit <ul style="list-style-type: none"> • Paper feed roller module • Double feed prevention roller 	KV-SS060	—
	Roller cleaning paper	KV-SS03	See "About the roller cleaning paper" (page 50).
	Ink cartridge	KV-SS021	For optional imprinter unit. For instructions on installation and removal, see "Installing the Imprinter Unit and Ink Cartridge" (page 67).
Optional Accessories	Imprinter unit	KV-SS014	Prints text and numbers on documents. Includes 1 ink cartridge. For instructions on installation, see "Installing the Imprinter Unit and Ink Cartridge" (page 67).

Note

- To purchase separately sold items, contact your dealer.

When to replace the rollers

As a rough guideline, we recommend to replace the paper feed roller module and double feed prevention roller after scanning 350,000 sheets of paper. ("350,000 sheets" is based on scanning normal paper. Depending on the type of paper and other factors, the actual lifetime for the rollers will differ.) In User Utility, you can check the number of sheets that have been scanned.

Replacing the Rollers

If double feeding or paper jam occurs frequently even after cleaning the roller (page 56), please call your dealer to order a "Roller exchange kit (KV-SS060)", and replace the paper feed roller module and double feed prevention roller.

1. Press and hold the power button for one second or more to turn off the unit's power.
2. Push the ADF door release (①) upwards, and open the ADF door (②).

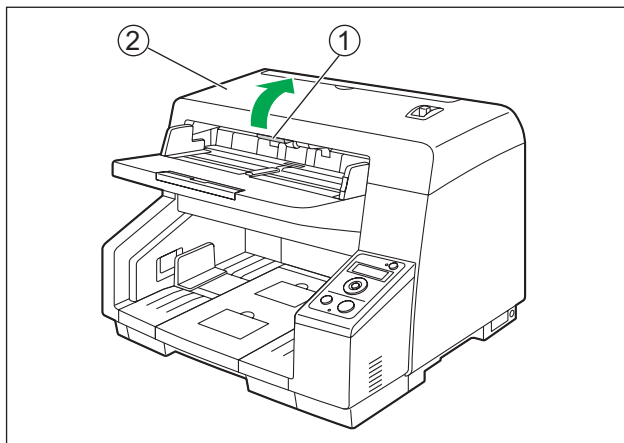

3. Move the lever (①) of the paper feed roller module in the order indicated by the arrow (➡, ↘), and then pull out the module towards you.

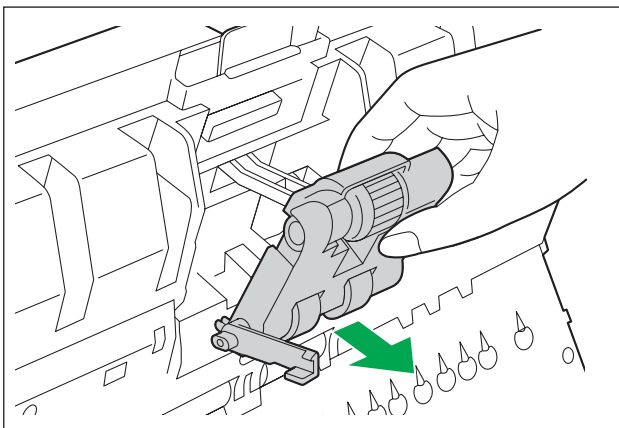
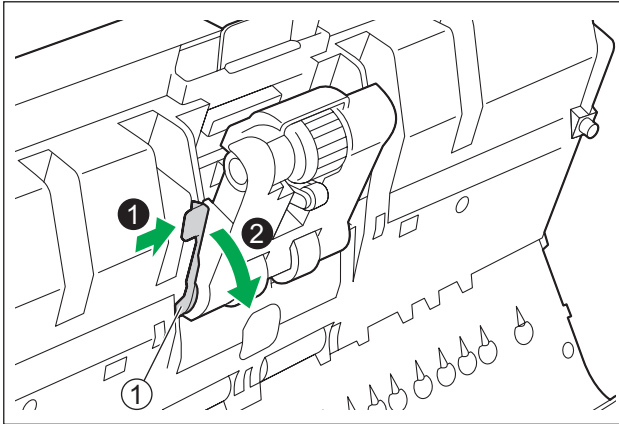

4. Open the "Roller exchange kit (KV-SS060)" (sold separately) and take out the new paper feed roller module.

5. Install the new paper feed roller module.

- With the lever (①) of the paper feed roller module lowered, insert both protrusions (②) into the grooves (③), and then slowly raise the lever in the direction indicated by the arrow until it clicks into place.

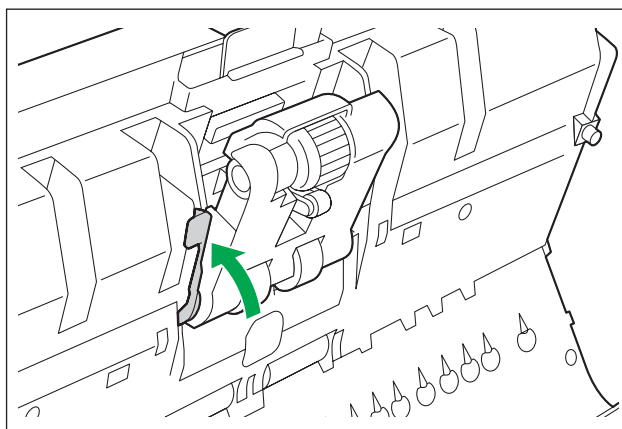
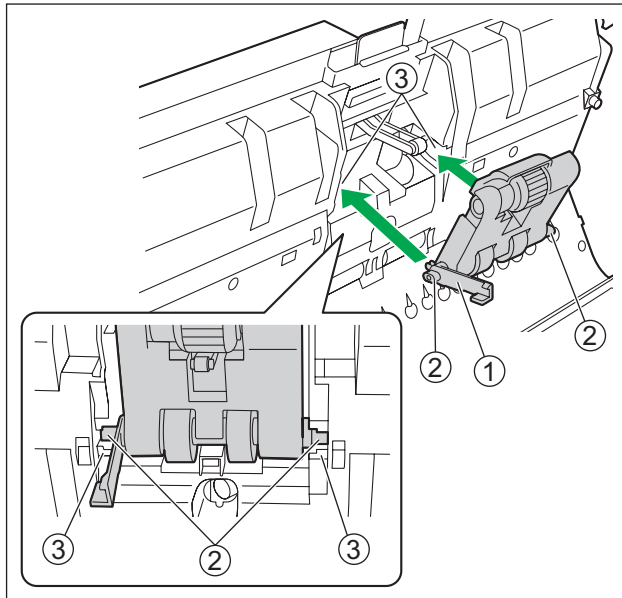
**Notice**

- Make sure that the paper feed roller module's lever is firmly set. If the lever is not firmly set, the lever or the paper feed roller module might become damaged or might not function correctly.

6. Use the indents (①) to pull the double feed prevention roller cover towards you to open it.

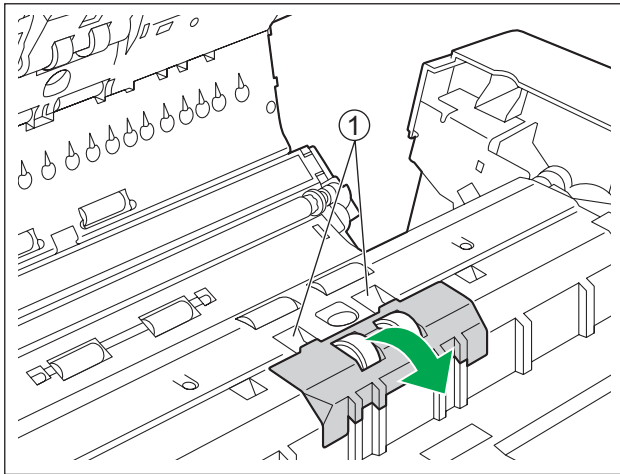

7. While pulling the tab (①) in the direction indicated by the arrow, lift the double feed prevention roller (②) in the direction of the arrow. Then, pull out the right shaft (when facing it) from the notch in the roller mount.

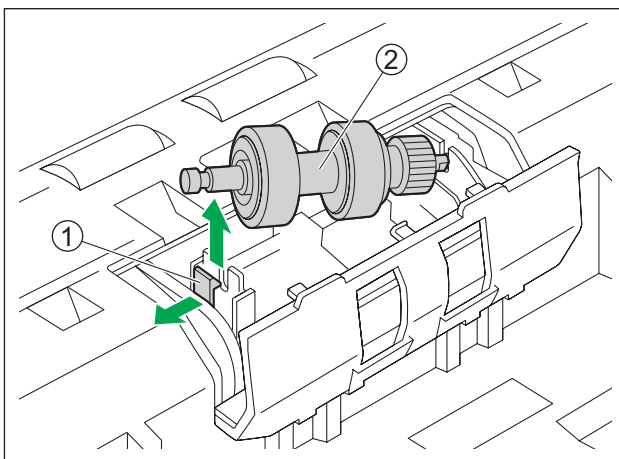

8. Open the "Roller exchange kit (KV-SS060)" (sold separately) and take out the new double feed prevention roller.

9. Install the new double feed prevention roller.

- Align the shaft that is shaped as indicated by ① with the notch in the roller mount (②), and then insert the shaft in the notch. Push the shaft on the opposite side (③) until it clicks into place.

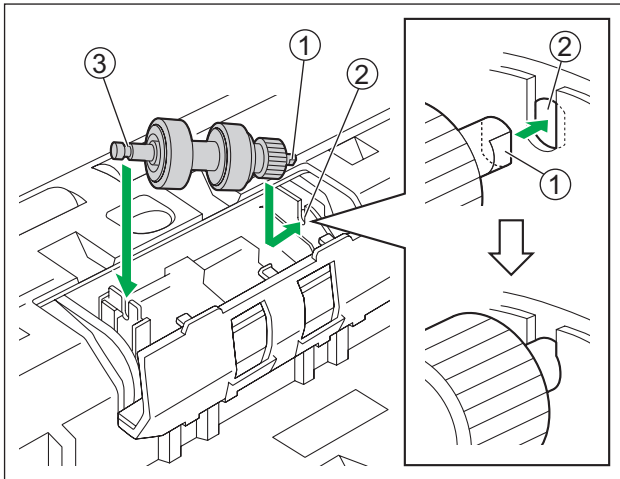
**Notice**

- After you install the double feed prevention roller, make sure that the shaft is inserted into the tab. If the roller is not installed correctly, it may cause double feeding or a paper jam.

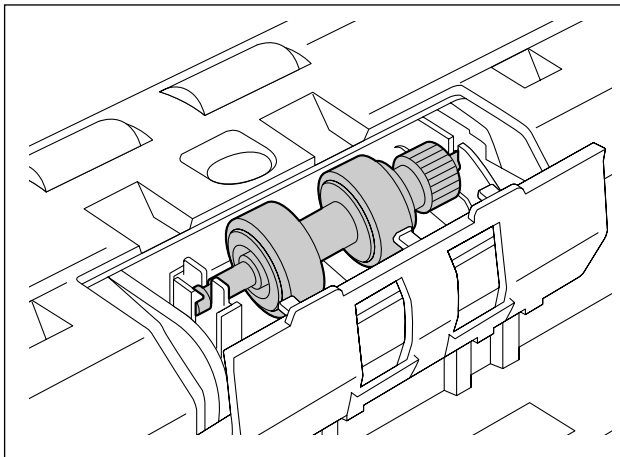

10. Push the double feed prevention roller cover until it clicks into place to close it.

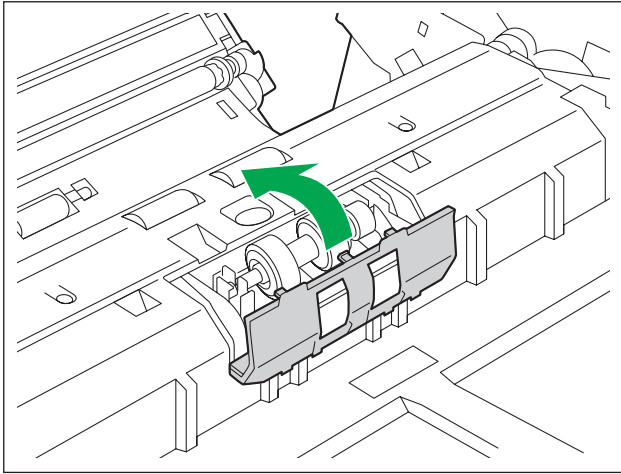

Notice

- Make sure that the double feed prevention roller cover does not stick up. If the double feed prevention roller cover is closed incompletely, damage or paper jams can occur.

11. Close the ADF door.

- Push both sides of the ADF door down slowly until it clicks into place.

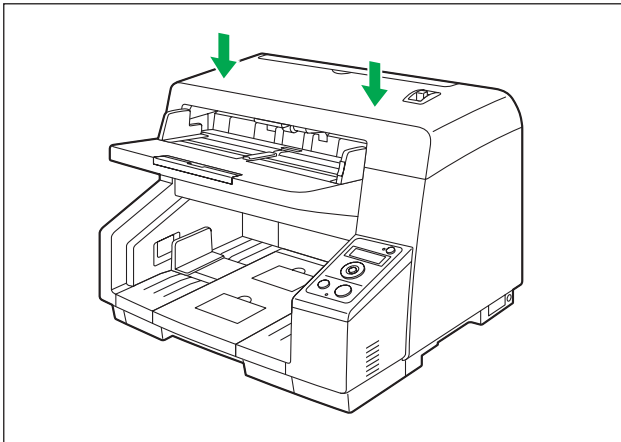

12. Press the power button to turn on the unit's power.

13. Reset the After Replace Roller Counter in User Utility to 0.

- For details, refer to the User Utility help.

Installing Optional Accessories

Installing the Imprinter Unit and Ink Cartridge

The imprinter prints on the face of the document before scanning. The printed text will also be scanned.

1. Press and hold the power button for one second or more to turn off the unit's power.
2. Open the imprinter door.

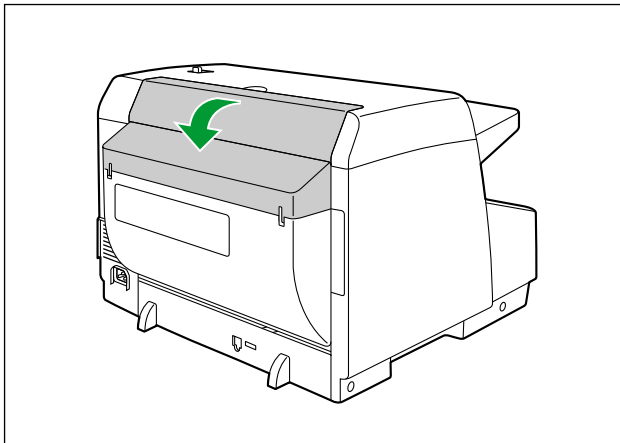

3. Connect the cable.

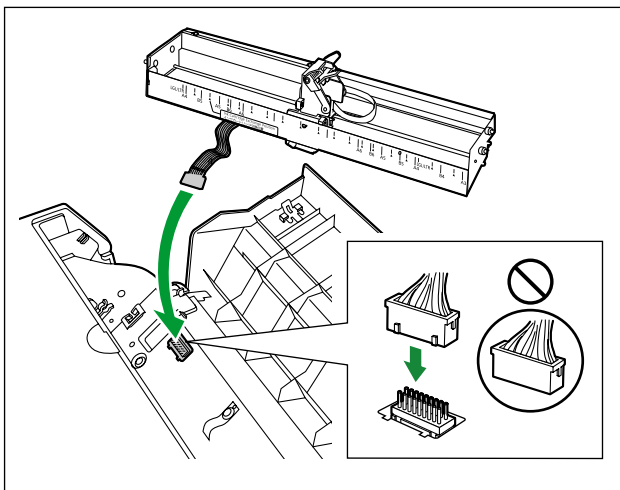

Notice

- Be sure to correctly match the rib with the slot prior to inserting the connector.

4. While keeping the direction of the imprinter as shown in the diagram below, insert the pins (①) on both sides into the guides, and insert the pins (②) on both sides into the guides until they are locked by the springs (③).

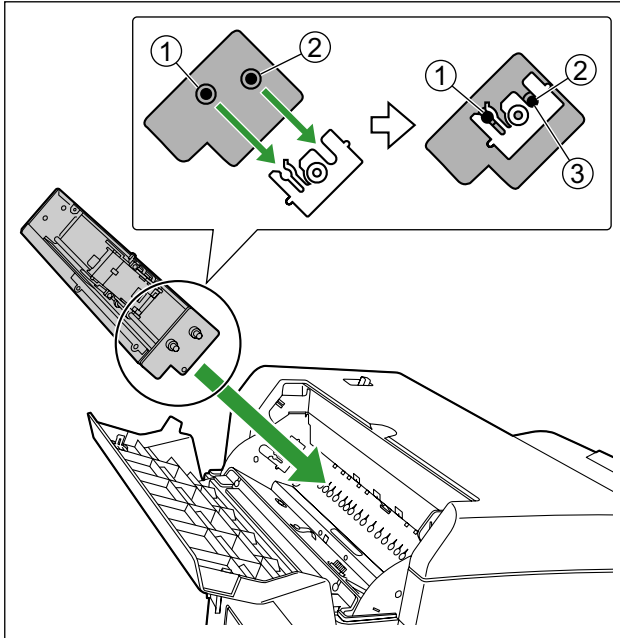

5. Remove the protective tape.

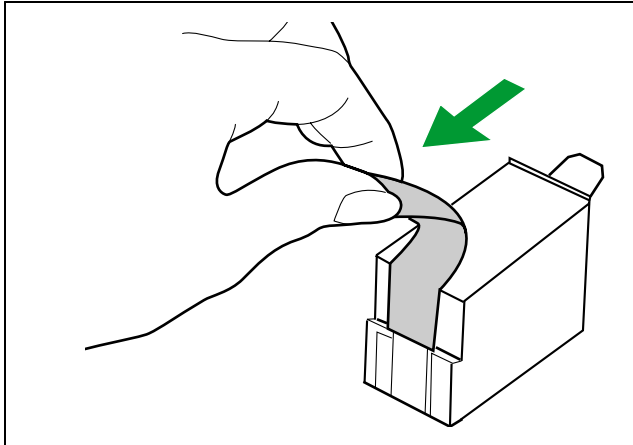

6. Move the carriage to the ink cartridge exchange position.

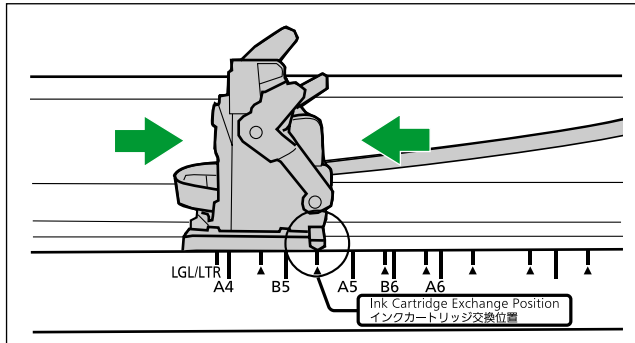

Notice

- Adjust the position following the label on the imprinter.

7. Insert the ink cartridge into the carriage.

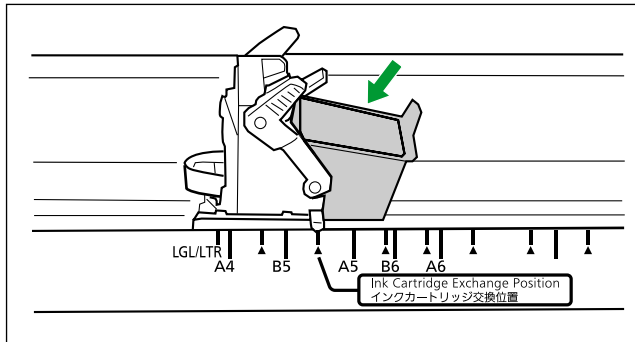

8. Lock the ink cartridge adjustment lever (①).

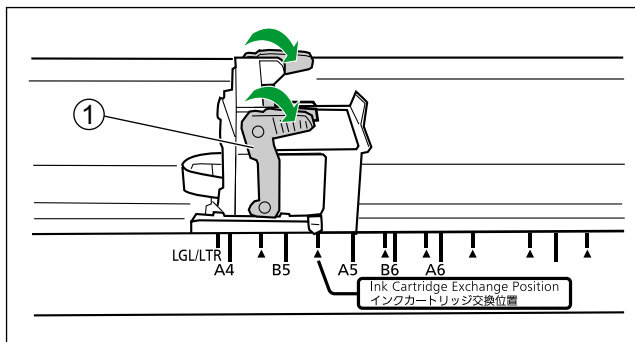

9. Close the imprinter door.

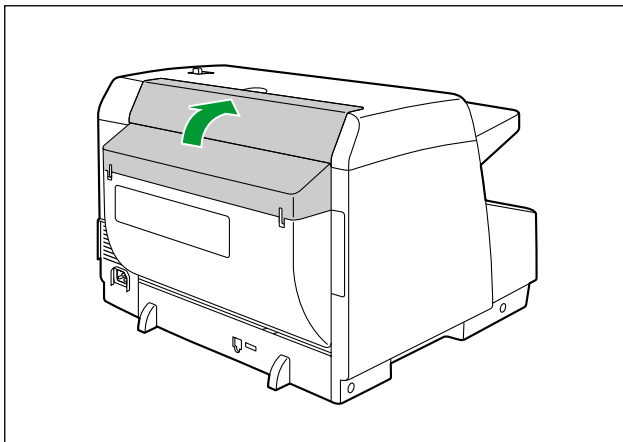

10. Press the power button to turn on the unit's power.

How to Remove the Ink Cartridge

Remove the old ink cartridge before installing a new ink cartridge.

1. Press and hold the power button for one second or more to turn off the unit's power.
2. Open the imprinter door.
3. Move the carriage to the ink cartridge exchange position.

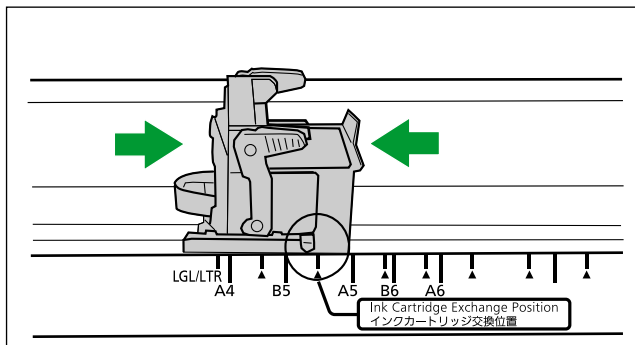

Notice

- Adjust the position following the label on the imprinter.

4. Pinch the ink cartridge adjustment lever (①) and lift it.

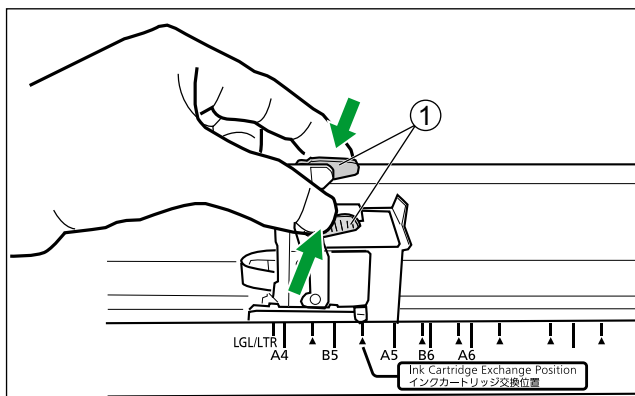

5. Remove the ink cartridge (①).

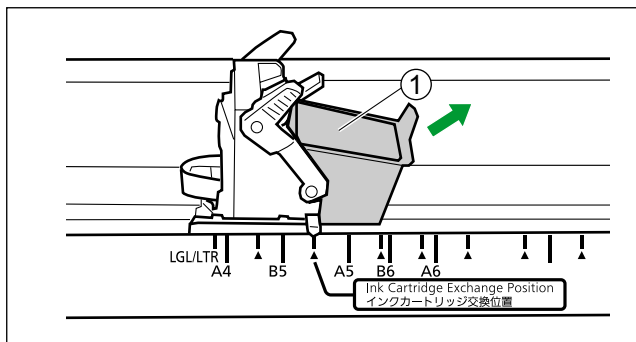

- For details about installing a new ink cartridge, refer to step 5 and after in "Installing the Imprinter Unit and Ink Cartridge" (page 67).

Printing

Adjusting the imprinter printing position

1. Move the carriage to the desired printing position, and align the indicator (①) with the "▲" mark (②).
 - The "▲" mark indicates the printing position. Printing is not available in any other position.

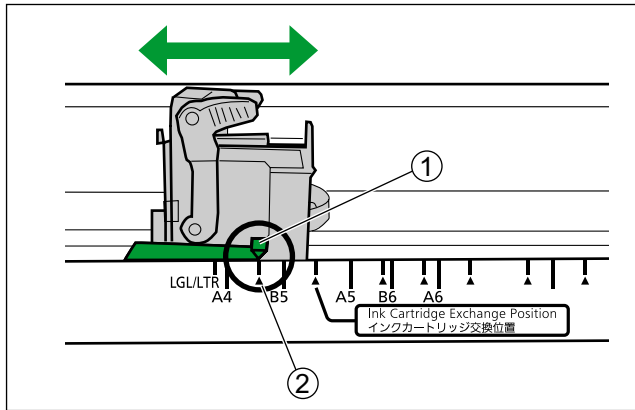

Printing Position

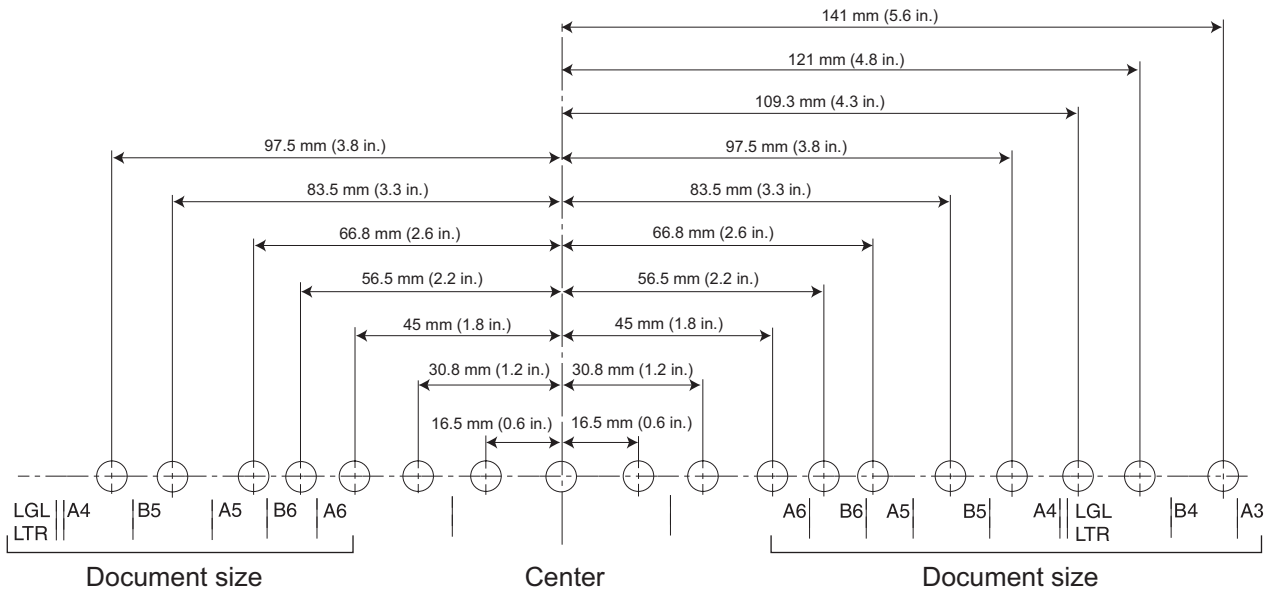

Printing

Printing can be set from the Image Capture Plus software and the TWAIN and ISIS drivers. For details, refer to the Image Capture Plus, TWAIN, or ISIS help.

Troubleshooting

If a problem occurs while the scanner is being used, check the following items and check the scanner status in User Utility. If the unit still malfunctions, turn it OFF, unplug the power cord and call for service.

Symptom	Possible Cause	Remedy
The LED (Green) does not light when the unit's power is turned ON.	The power cord is not plugged in.	Insert the power plug firmly.
The computer does not recognize the scanner. The scanner is not functioning correctly.	The scanner is not connected to the computer correctly.	Connect the USB cable correctly.
	The software is not installed correctly.	Uninstall the software from the computer (page 79), and then install the software again (page 20).
	The scanner is connected via USB hub.	Do not connect via USB hub.
	There is a problem with the USB cable.	Make sure to use the included USB cable.
	The unit's power was turned OFF because no operation was performed for a certain period of time.	Press the power button to turn ON the unit's power.
Scan speed is slow.	The scanner is connected over a USB 1.1 connection.	Connect over USB 2.0 / USB 3.0.
The document has been loaded on the feed tray, but the scanner does not start scanning.	The document is not loaded properly.	Load the document correctly. (page 26)
	The sensor cannot detect the document as the edge of the document is curled.	Flatten the document (page 24) and load it again (page 26).

Symptom	Possible Cause	Remedy
Double feeding occurs frequently or the scanner stops loading while scanning.	The paper feed roller, separation roller, double feed prevention roller, drive rollers, or free rollers are dirty.	Clean the paper feed roller, separation roller, double feed prevention roller, drive rollers, and free rollers. (page 56)
	The sensors or reflectors are dirty.	Clean all of the sensors and the reflectors. (page 54)
	The paper feed roller, separation roller, or double feed prevention roller have become worn down.	Replace the paper feed roller module, and double feed prevention roller. (page 61)
	Right and left sides of the document to be scanned are not the same in height, because of curling or folding.	Flatten the document (page 24) and load it again after reducing the pages.
	The document is printed on an unsupported type of paper or thick paper.	Make a copy of the document on paper of an acceptable type and thickness (page 23), and scan the copy.
	The length of the paper is too short.	Make a copy of the document on paper of an acceptable size (page 23), and scan the copy.
	The scanning method is set to manual.	Set the scanning method to continuous scanning (Auto) with the manual feed selector. (page 11)
	The document is not aligned correctly.	Realign the document. (page 26)
	The document set on the feed tray has too many pages.	Remove pages from the document until it is under the limit mark on the document guides.
Paper jams occur frequently.	The document is wrinkled.	Smooth out the document.
	The paper feed roller, separation roller, double feed prevention roller, drive rollers, or free rollers are dirty.	Clean the paper feed roller, separation roller, double feed prevention roller, drive rollers, and free rollers. (page 56)
	The sensors or reflectors are dirty.	Clean all of the sensors and the reflectors. (page 54)
	The document is not aligned correctly.	Realign the document. (page 26)
	The document set on the feed tray has too many pages.	Remove pages from the document until it is under the limit mark on the document guides.

Symptom	Possible Cause	Remedy
Scanned image is skewed.	The document guides are not adjusted to the size of the document to be scanned, or the document to be scanned is set slanted on the feed tray.	Adjust the document guides properly to the size of the document to be scanned. (page 26)
	Right and left sides of the document to be scanned are not the same in height, because of curling or folding.	Flatten the document (page 24) and load it again after reducing the pages.
The scanned document is blank.	The wrong face (blank face) of the document is being scanned.	Load the document with the side to be scanned facing up.
Vertical lines appear on the scanned document.	The scanning glass is dirty.	Clean the conveyor and self-cleaning brushes (page 53), the ion outlets (page 54), and then clean the scanning glasses (F and B) (page 59).
The scanning density is uneven.	The scanning glass is dirty.	Clean the scanning glasses (F and B). (page 54)
	The quantity distribution of light varies.	Adjust shading. (page 78)
The color of the scanned document is extremely different from the original document.	The settings of the computer monitor are wrong.	Adjust the computer monitor settings.
Dark spots or noise appear on the scanned documents.	The scanning glass is dirty.	Clean the conveyor and self-cleaning brushes (page 53), the ion outlets (page 54), and then clean the scanning glasses (F and B) (page 59).
There is noise or wave patterns (moire pattern) on the scanned image.	The scanning resolution settings, combined with patterns within the scanned image, may cause this problem.	Change the scanning resolution, and perform scanning again.

If you still experience problems after following these suggestions, please contact our Technical Support Department at 1-800-726-2797 for further assistance. (U.S.A. only)

Error Messages (KV-S5076H only)

Error codes corresponding to the scanner status are displayed on the LCD.

Also, when the scanner is connected to a computer, simple messages are displayed on the LCD.

For details about the error codes and messages, check in User Utility.

Error Code	Cause	Remedy
U11 U12 U13	The paper has jammed in the feed tray area.	Open the ADF door, and remove the paper.
	The sensors are dirty.	Clean the sensors. ^{*1}
U14 U16	The paper has jammed in the exit tray area.	Open the ADF door, and remove the paper.
	The sensors are dirty.	Clean the sensors. ^{*1}
U18	Paper has been left in the scanner.	Open the ADF door, and remove all the paper left inside.
	The sensors are dirty.	Clean the sensors. ^{*1}
U23	A double-feed error has occurred.	Open the ADF door, and remove the jammed paper.
U25 U26	A stapled document has been detected.	Open the ADF door, and remove all the paper left inside.
U30	The ADF door is open.	Close the ADF door.
Fxx	A system error has occurred.	Contact your dealer.

^{*1} For details, see "Cleaning the Ion Outlets and Sensors" (page 54).

Shading Adjustment

About shading adjustment

The shading adjustment function corrects variations in the lamp intensity and pixel sensor sensitivity, and reduces unevenness in density in scanned images. It can be carried out by means of the User Utility using the special shading paper, which is provided with this scanner.

When shading adjustment is required

Perform shading adjustment when the density and brightness of sections of scanned images is considerably uneven, or when image quality does not improve after cleaning the inside of the scanner.

Before proceeding with the shading adjustment

Before beginning shading adjustment, thoroughly clean the scanning glass (F), scanning glass (B), conveyors in the scanning area, self-cleaning brushes, ion outlets, and all rollers.

If you perform shading adjustment while these parts are dirty, lines will appear on scanned images.

Shading adjustment procedure

1. Start the User Utility.
2. Click [User Shading...] on the main menu, and operate as the image display dictates.

Note

- For further details, refer to section "[User Shading]" in the help for User Utility.

Notice

- If the shading adjustment has not been performed properly, then lines might appear on scanned images even after adjusting the shading or lines might not be eliminated even after cleaning the scanning glass. Clean the parts, and then adjust the shading again.

Deleting Installed Software

If you want to remove the software that is installed on your computer, follow the procedure below to uninstall them.

1. In [Control Panel], open [Uninstall a program].
 - In Windows XP, select [Add or Remove Programs].
2. Select the item that you want to uninstall.
 - The software is displayed with the program names below:

Software	Program Name
Device driver	Panasonic Document Scanner Device Driver X.XX ^{*1}
TWAIN	KV-S5076H KV-S5046H TWAIN Driver
ISIS	KV-S5076H KV-S5046H ISIS Driver
Image Capture Plus	Image Capture Plus
User Utility	Panasonic Scanner User Utility
Manuals	Panasonic Scanner Manuals

^{*1} "X.XX" and the number that follows a program name are the software version. When you upgrade the software, the numbers above may be different from the actual software version.

3. Follow the instructions on the screen.

Repacking Instructions

It is highly recommended that you keep the original carton and *ALL* packing materials. If you need to transport or ship the scanner, please follow these instructions.

Note

- Improper repacking of the scanner may result in a service charge to repair the scanner.
- Please use the original carton and all of the original packing materials.
- The scanner should be handled in the correct (horizontal) position.

Required Materials

- Original scanner carton and packing materials
 - Shipping tape and scissors
1. Unplug the power cord from the outlet, and remove the power cord and USB cable from the scanner.
 2. Remove the exit support sheet.
 3. Return the exit stoppers and exit extension tray to their original (non-extended) positions.
 4. Remove the double feed prevention roller (page 64).

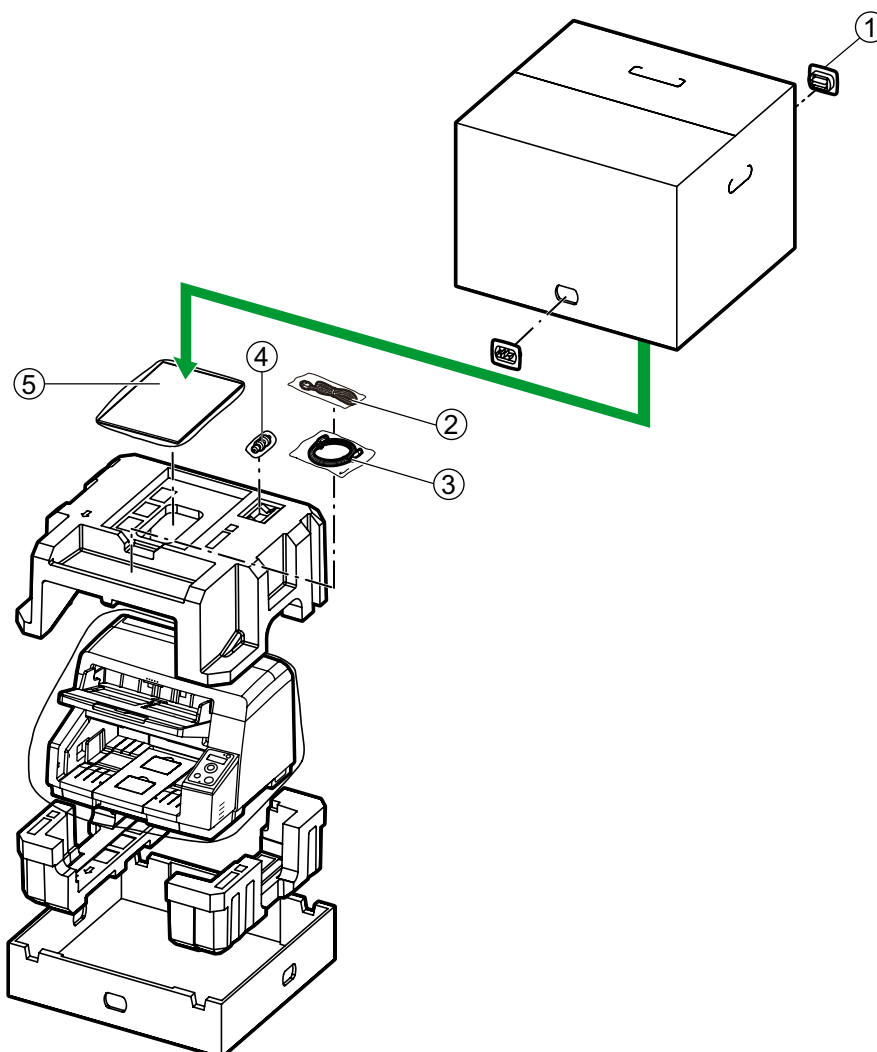
5. Pack the scanner.

- ① Joint
- ② Power cord
- ③ USB cable
- ④ Double feed prevention roller
- ⑤
 - Software / Manual CD-ROM
 - Quick Installation Guide
 - Shading paper
 - Roller cleaning paper
 - Exit support sheet

Specifications

Item		KV-S5076H	KV-S5046H	
Scanning	Scanning face		Duplex	
	Scanning method		Color CIS (600 dpi)	
	Scanning speed ¹ (landscape)	Binary / color (200 dpi, 300 dpi)	Simplex A4: 100 pages/min. Duplex A4: 200 images/min.	Simplex A4: 80 pages/min. Duplex A4: 160 images/min.
	Resolution		100 – 600 dpi (1 dpi step) Optical: 300 dpi / 600 dpi (Automatic switch)	
	Paper ²	Width	48 – 307 mm (1.9 – 12.09 in.)	
		Length	When feeding multiple sheets: 70 – 432 mm (2.8 – 17 in.) When feeding one sheet: 70 – 2,540 mm (2.8 – 100 in.) ³	
		Thickness	0.04 – 0.2 mm (1.6 – 7.9 mils) Note: 1 mil = 0.001 in.	
		Paper thickness for feeding	20 – 157 g/m ² (5 – 42 lb.)	
	Feed tray capacity		300 sheets (75 g/m ² [20 lb.], 80 g/m ² [21 lb.] New Paper) ⁴ 350 sheets (64 g/m ² [17 lb.] New Paper) ⁵	
	Stapled document detection		Available	—
	Self-cleaning brushes		Available	Available
	Ionizer		Available	—
Mechanical deskew		Available	—	

- dpi: dots per inch

¹ The scanning speed differs depending on the host computer, the operating system, the application, the measuring method, the quantity of data in the image, and the paper type. The scanning speed depends on a measuring method of Panasonic.

² Scan quality cannot be guaranteed for documents with a non-standard size.

³ Using "Long Paper", you can scan long documents by splitting them into smaller parts. For details about "Long Paper", refer to the Image Capture Plus, TWAIN, or ISIS help.

⁴ For documents less than 100 mm (3.94 in.) in length, the maximum is 150 sheets with a combined thickness of 15 mm (0.59 in.) or less.

⁵ For documents less than 100 mm (3.94 in.) in length, the maximum is 175 sheets with a combined thickness of 15 mm (0.59 in.) or less.

"Weight in pounds" of paper represents the weight of 500 (432 × 559 mm [17 × 22 in.]) sheets.

Item		KV-S5076H	KV-S5046H	
Scanner	External dimensions (Width × Depth × Height)	468 × 444 × 344 mm (18.5 × 17.5 × 13.5 in.)		
	Weight	18 kg (39.5 lb.)		
	Power requirement ¹	AC100 – 127 V, 50/60 Hz, 1.5 A	AC100 – 127 V, 50/60 Hz, 1.5 A	
		AC220 – 240 V, 50/60 Hz, 0.8 A	AC220 – 240 V, 50/60 Hz, 0.8 A	
	Power consumption (For AC100 – 127 V models)	Scanning	90 W or less	90 W or less
		Ready	30 W or less	30 W or less
		Sleep	1.2 W or less	1.2 W or less
		Power OFF	0.3 W or less	0.3 W or less
	Power consumption (For AC220 – 240 V models)	Scanning	90 W or less	90 W or less
		Ready	30 W or less	30 W or less
Sleep		1.2 W or less	1.2 W or less	
Power OFF		0.3 W or less	0.3 W or less	
Operating Environment		Temperature: 10 – 35 °C (50 – 95 °F) Humidity: 20 – 80 % RH		
Storage Environment		Temperature: 0 – 40 °C (32 – 104 °F) Humidity: 10 – 80 % RH		

¹ The power requirement differs depending on the country/area. Do not use a power source that does not meet the power source specifications marked on the unit. The power source specifications of this unit is listed on the rating name plate.

Index

A

AC inlet 12
 Accessories 10
 ADF door 11, 16
 ADF door release 11, 16
 Adjusting the imprinter printing position 73

B

Background color switch function 2, 38

C

Cleaning the inside of the scanner 49
 Conveyor 53
 Ion outlets and sensors 54
 Rollers 56
 Scanning backgrounds 58
 Scanning glasses 59
 Cleaning the outside of the scanner 48
 Consumables 60
 Control panel 11, 13
 Control sheet 3, 42
 Cursor button 13, 41

D

Document feeder 48
 Document guides 11, 26
 Document guides selector 11, 32
 Documents
 Acceptable documents 23
 Scanning documents 26
 Unacceptable documents 25
 Double feed detection function 2
 Double feed prevention roller 10, 17
 Double Feed Skip (DFS) function 2, 13

E

Error messages 77
 Exit extension tray 11, 29
 Exit guides 11, 30
 Exit slot 46, 48
 Exit stoppers 11, 29
 Exit support sheet 10, 30
 Exit tray 11
 External dimensions 83

F

Fan exhaust vent 12, 48
 Feed extension tray 11, 27
 Feed tray 11, 27
 Feed tray capacity 82

I

Imprinter door 12, 67
 Imprinter unit 60, 67

Ink cartridge 60, 67
 Installation location 15
 Ionizer 82

L

LCD 13, 41
 LED (Green) 13, 14
 LED (Red) 13, 14
 Limit mark 27, 34

M

Manual feed selector 11, 31
 Mechanical deskew 2, 82

O

OK button 13, 41
 Operating Environment 83
 Optional accessories 60

P

Paper 82
 Paper feed roller module 61
 Paper jams 25, 45
 Power button 13, 21
 Power consumption 83
 Power cord 10, 12, 19
 Power requirements 83
 Precautions 8

Q

Quick Installation Guide 3, 10

R

Reference plate 53, 58
 Reflectors 55
 Repacking 80
 Replacing the rollers 61
 Resolution 82
 Roller cleaning paper 9, 10, 50, 60
 Roller exchange kit 60
 Rollers
 Double feed prevention roller 57, 61
 Drive rollers 57
 Free rollers 57
 Paper feed roller 57
 Separation roller 57

S

Scan Button Setting Tool 3, 39
 Scanning face 82
 Scanning glass 59
 Scanning method 82
 Scanning speed 82
 Self-cleaning brushes 82
 Self-cleaning function 2
 Sensors
 Double feed detector 54

Paper sensor 54
Skew sensor 54
Slip detect sensor 54
Starting sensor 54
Waiting sensor 54
Shading adjustment 78
Shading paper 10, 78
Skip button 13
Software
 Install 20
 Uninstall 79
Software / Manual CD-ROM 3, 10, 20
Specifications 82
Stapled document detection 2, 25, 82
Start/Stop button 13
Starting up applications automatically
 Single Touch Scanning 39
 Touch Free Scanning 39
Storage Environment 83

T

Troubleshooting 74

U

USB cable 10, 19
USB connector 12
User Utility 3, 14, 66

W

Weight 83

